

# ASSEMBLY INSTRUCTIONS FOR GARDEN SHRED QBSH

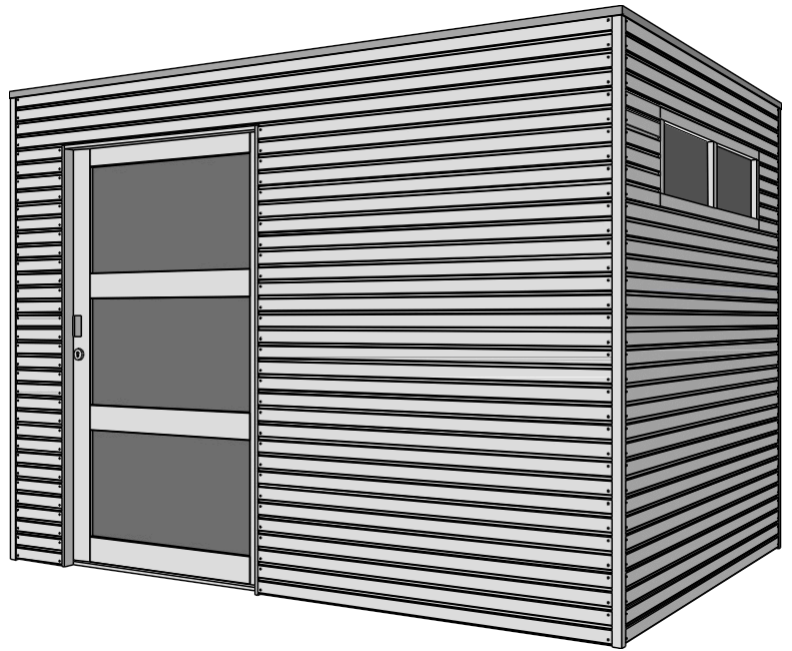

**WOODLANDS**  
QUALITY CABINS

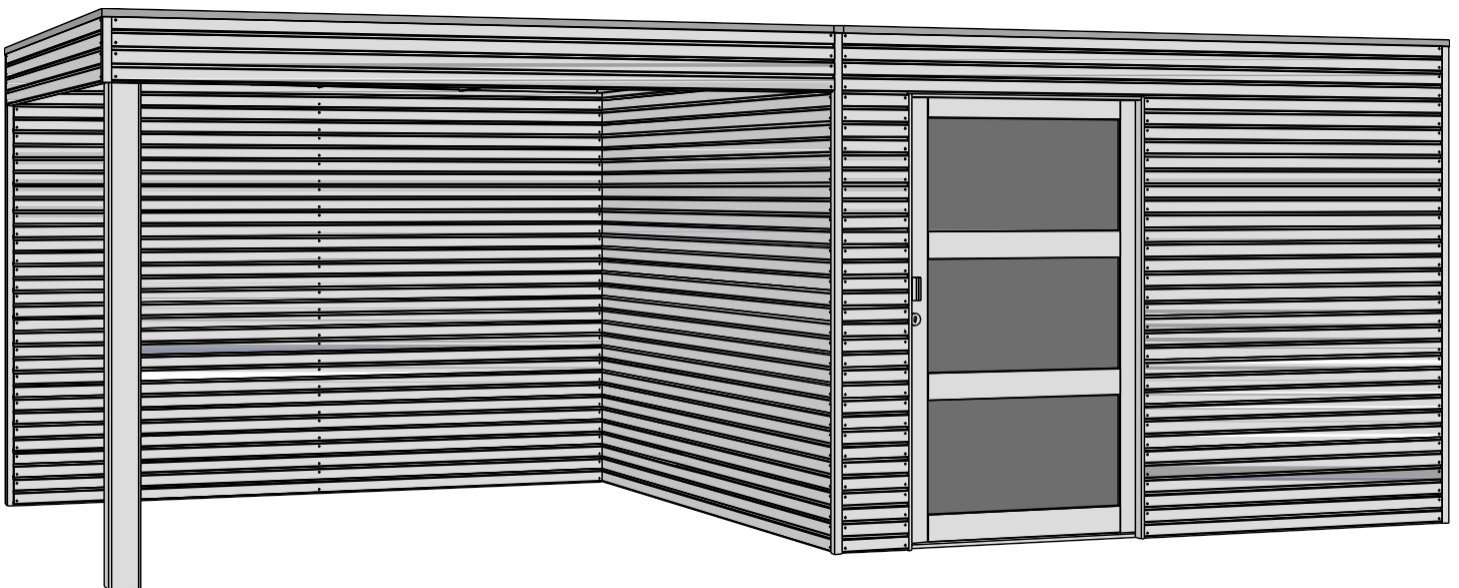

## ASSEMBLY INSTRUCTIONS QBSH

Congratulations on the purchase of your garden shed.

If you read the assembly instructions carefully, you will enjoy your purchase for many years to come.

### Tips and advice

Before you start assembly, we would like to give you some important information that deserves your attention.

**A  
I  
A  
2**

**TREATMENT** Have you purchased a garden shed made from an untreated natural product? This type of wood still needs to be treated to ensure a long lifespan. It is best to seek guidance from a specialist in the field when choosing your treatment product and maintaining your garden shed. Use only products that penetrate the wood and protect it against moisture, wind and weather, as well as against insects and fungi. Do not use products that are so viscous that they prevent a good fit between tongue and groove and at the corner joints. You only have the opportunity to treat the tongue and groove **before** assembly. It is very important to **treat** all parts **on all sides**. You must therefore also treat **the inside** of the garden shed.

**TREATMENT** Have you purchased a garden shed that has been pressure-impregnated? Gardenas wax impregnation significantly extends the lifespan of your product and provides temporary protection against moisture. After the first summer season, you will need to apply an extra protective layer of stain or other paint. This will prevent the wood from splitting and warping. It is best to seek advice from a specialist when choosing your treatment product and for the maintenance of your shed. Use only products that penetrate the wood and protect it against moisture. Pressure impregnation itself protects the shed against rot, mould and insects. The treatment product therefore only needs to be water-repellent and suitable for outdoor use (= UV-resistant).

**B**

**FOUNDATION** It is advisable to install a waterproof concrete base. It is of the utmost importance that your shed is level and remains so. Bear in mind that if your structure is not kept level properly after installation, this may result in gaps and deformations in the shed, amongst other issues. Ensure that ground moisture and other moisture cannot penetrate the wood by providing adequate ventilation for the shed and treating **the interior** against moisture. Seal the joint between the shed and its base with silicone (not supplied). Anchor all walls to the base (e.g. using L-brackets, not included) to protect against stormy weather.

**C**

**UNPACKING** Unpack the parts for your shed from their packaging two days before assembly, but keep them sheltered from the rain. This allows the wood to acclimatise to the humidity. Now carry out a full check using the enclosed parts list. Complaints regarding materials will not be accepted if the parts have been painted. Complaints must reach us no later than 8 days after delivery.

**D**

Wood is a natural product. This means that slight variations may occur. What are **acceptable** variations?

- Knots,
- Fallen knots no larger than a thumb,
- Fallen knots or slight damage to the edges (tongue and groove) provided that coverage is guaranteed during assembly
- Discolouration in the wood,
- Straight cracks that do not split the plank, splitting cracks no longer than 12 cm,
- Resin pockets of up to 5 cm,
- Wood that is slightly bowed, if assembly remains possible.

**E**

Ensure you **anchor** your storage unit to its base (e.g. L-bracket, not included).

**F**

To prevent splitting, we recommend pre-drilling with a drill bit smaller in diameter than the screw when screwing.

**G**

Has a part been damaged during assembly, or are you having trouble figuring it out?

Our after-sales service is at your disposal:

- during office hours by telephone: +32 (0)52 21 95 71
- by fax: +32 (0)52 22 09 03 or
- by email [sav@gardenas.be](mailto:sav@gardenas.be)
- if you notice any damage to the parcel, please let us know within 48 hours.

## CONCEPT



**ATTENTION!** The planks are glued to the corner profiles using the supplied wood glue. Gluing is essential to ensure the garden shed remains square. Assembly without glue will void the warranty. As long as the glue is not dry, you can still make small adjustments; not afterwards! So make sure you build the walls perfectly plumb from the start!



You will also need clear silicone in the corners (not included).

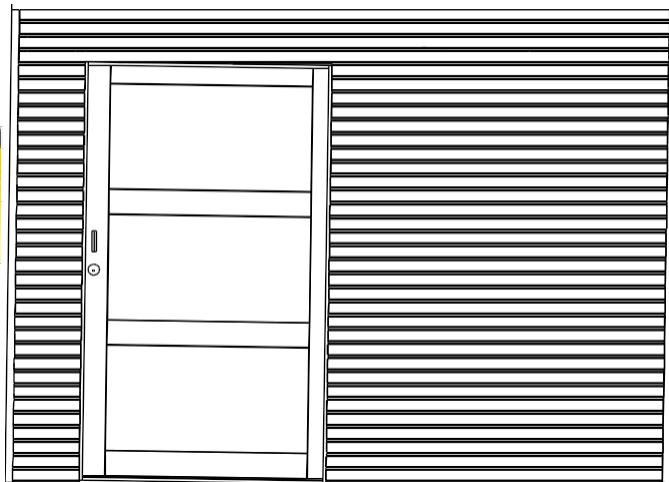
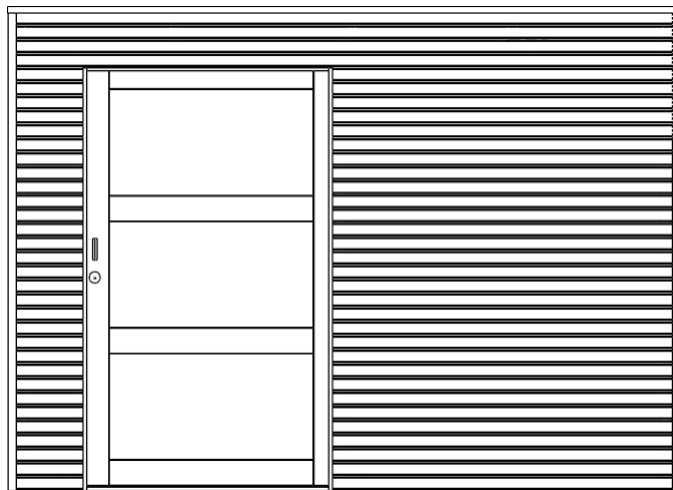

Once you have checked the parts against the accompanying parts list, you can start assembling. What do you need? A saw, a try-square, a spirit level, a piece of auxiliary wood, a screwdriver, 2 ladders, a rubber mallet, a drill bit, silicone, plugs suitable for your ground and a thumbtack. At least 2 adults are required for the assembly. Keep children and pets away during assembly.

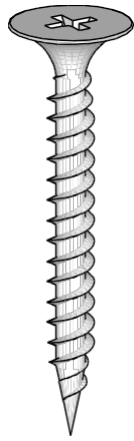

Screw = Pre-drill! To prevent the wood from splitting when screwing, you should always pre-drill using a drill bit with a diameter equal to the diameter of the screw core.

I.

Assembling the door frame.

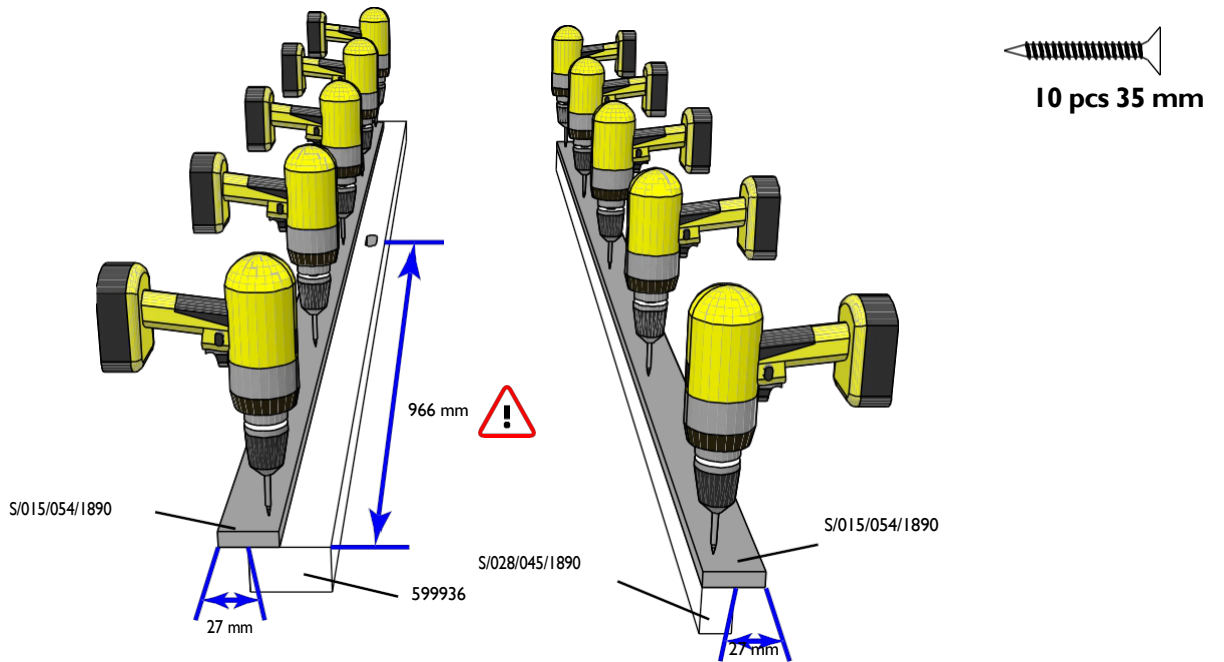

## 2.

### First layer of planks

Apply a bead of silicone over a length of 20 cm to the lower part of the corner profiles and the assembled door frames from step 1.

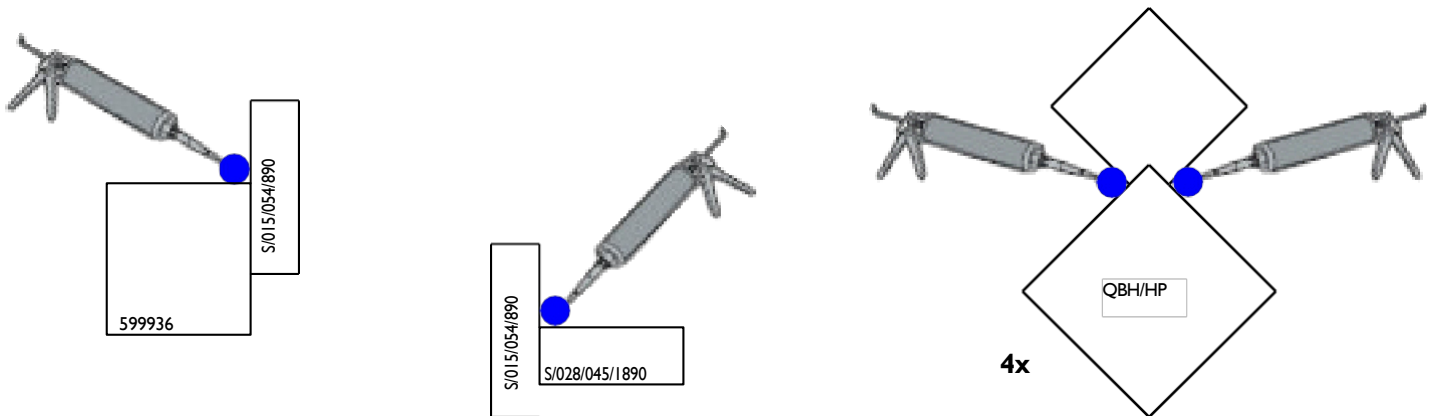

Refer to the diagrams and the references in the parts list to determine which planks you need for the base layer.

Apply a bead of glue to the ends of each plank and screw the plank through the pre-drilled holes in the corner profile / door frame. Ensure everything is square. **Attention!** On the corner profiles, the 'smaller' beam is on the outside of the structure.

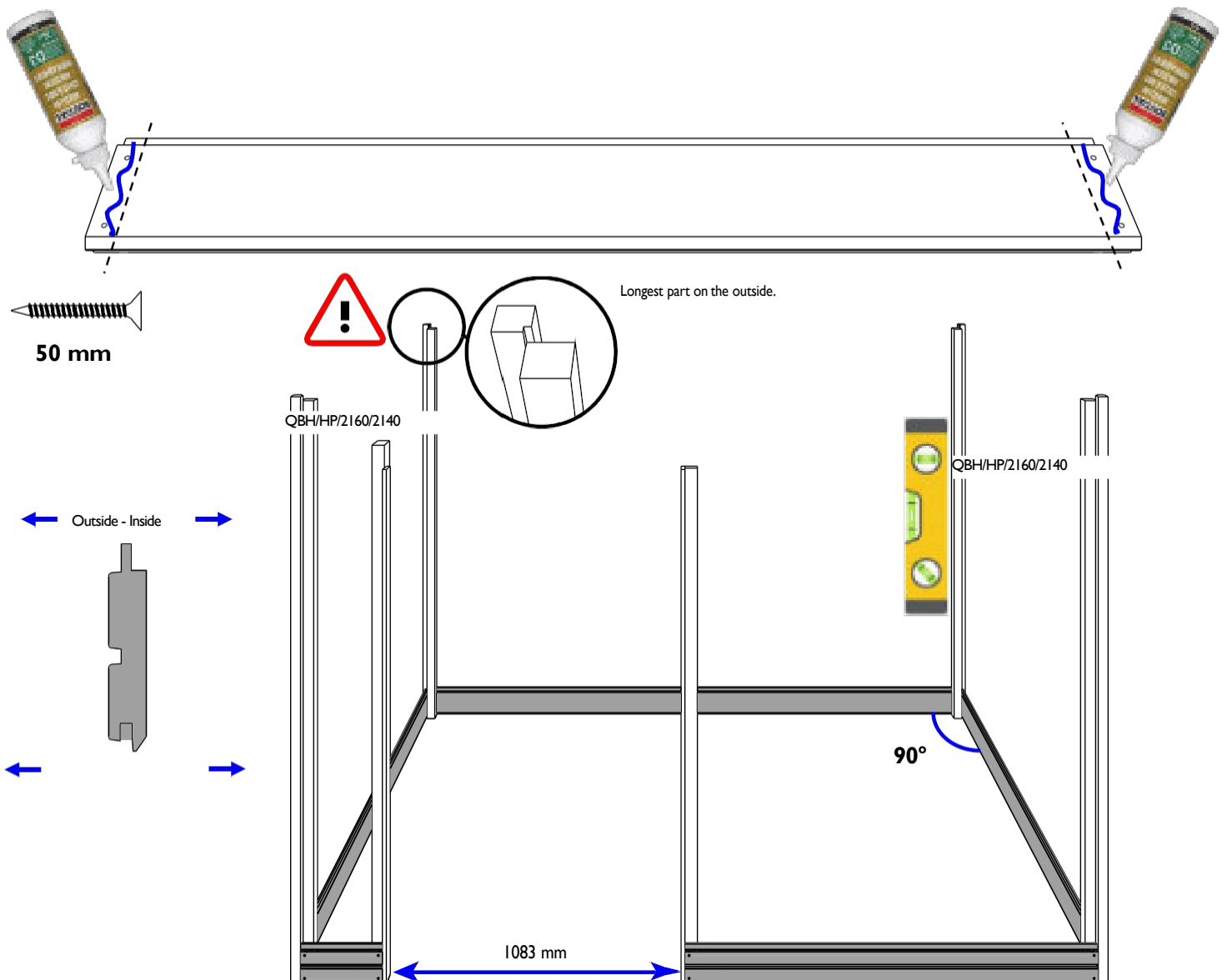

3.

### Anchoring to the ground

Secure a 60x60x40 angle bracket to the left and right of the door opening. Anchor to the ground (plugs not supplied). Also ensure suitable ground anchoring for the other walls (not supplied).

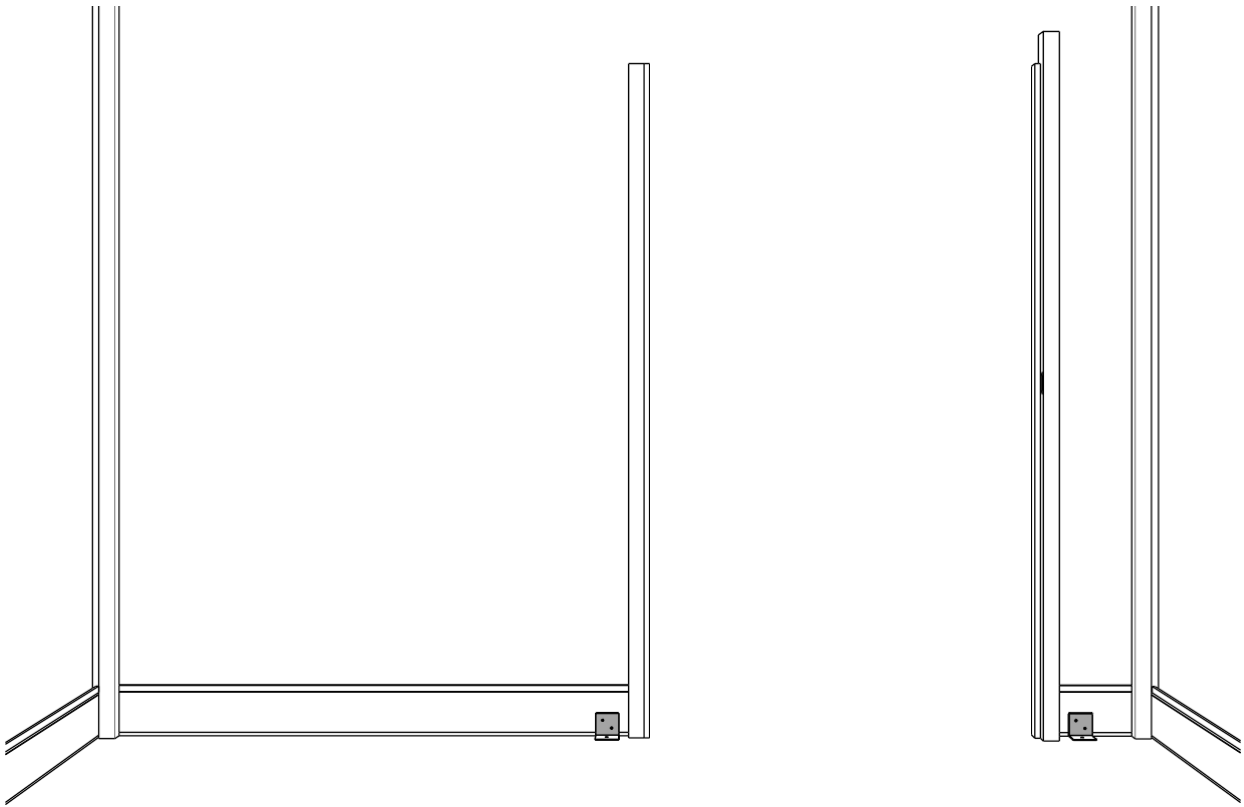

4.

### Securing the centre brace

 50 mm

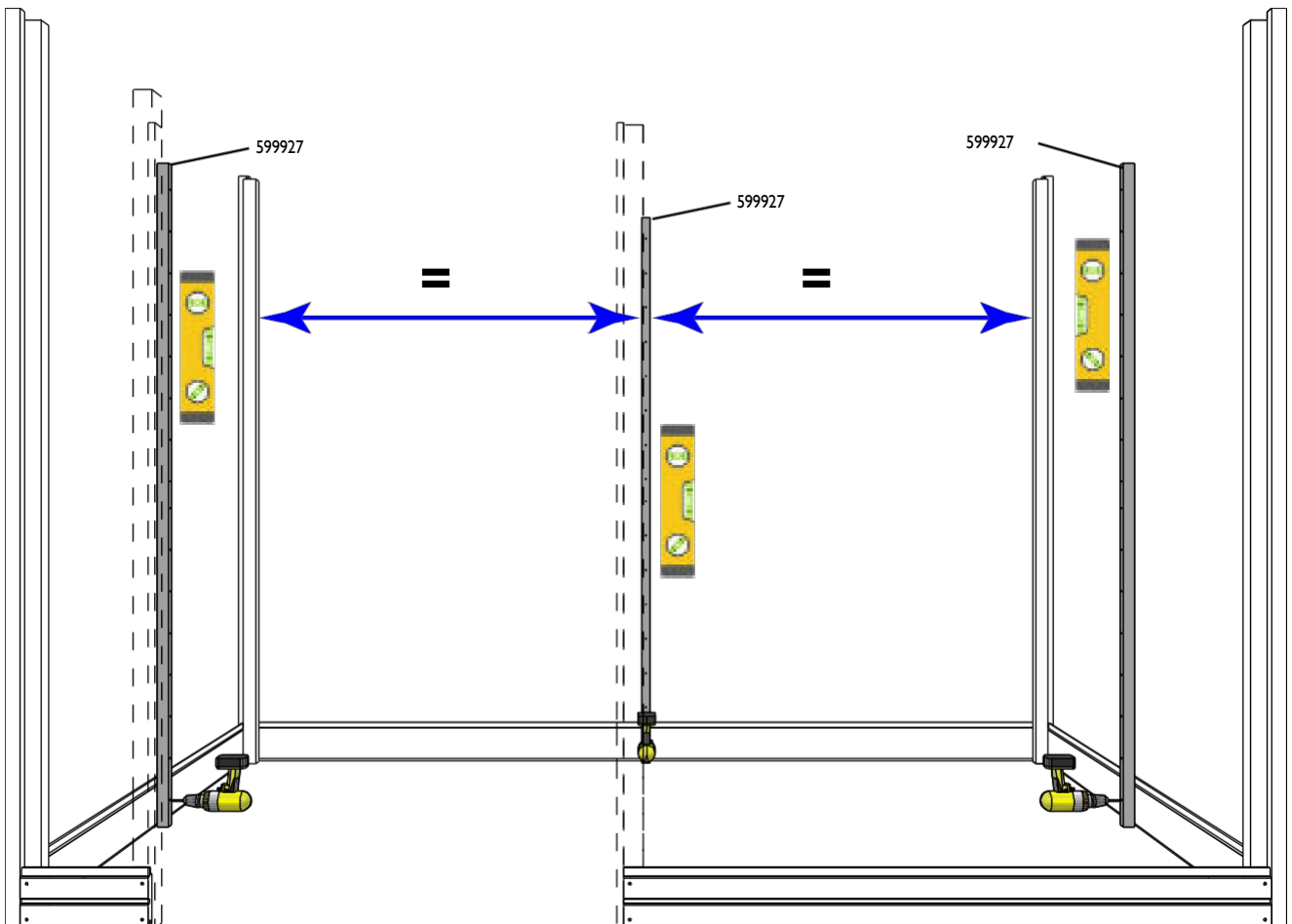



**ATTENTION!** This step is crucial in the assembly of your garden shed!  
If you do not do this, the planks cannot 'move' and the walls may warp due to fluctuating humidity.  
Furthermore, the openings for the door and window will not fit and the overall height will be incorrect.



## 5.

### Marking lines

- a. Secure (e.g. with a thumbtack) a measuring tape to the side of a corner post, with the bottom end flush with the flat side of the already placed plank. Attach a second tape above the first one.
- b. Mark every 126 mm on the corner profile.  
Repeat on the other side of the profile and on every other corner profile and on the door frame.

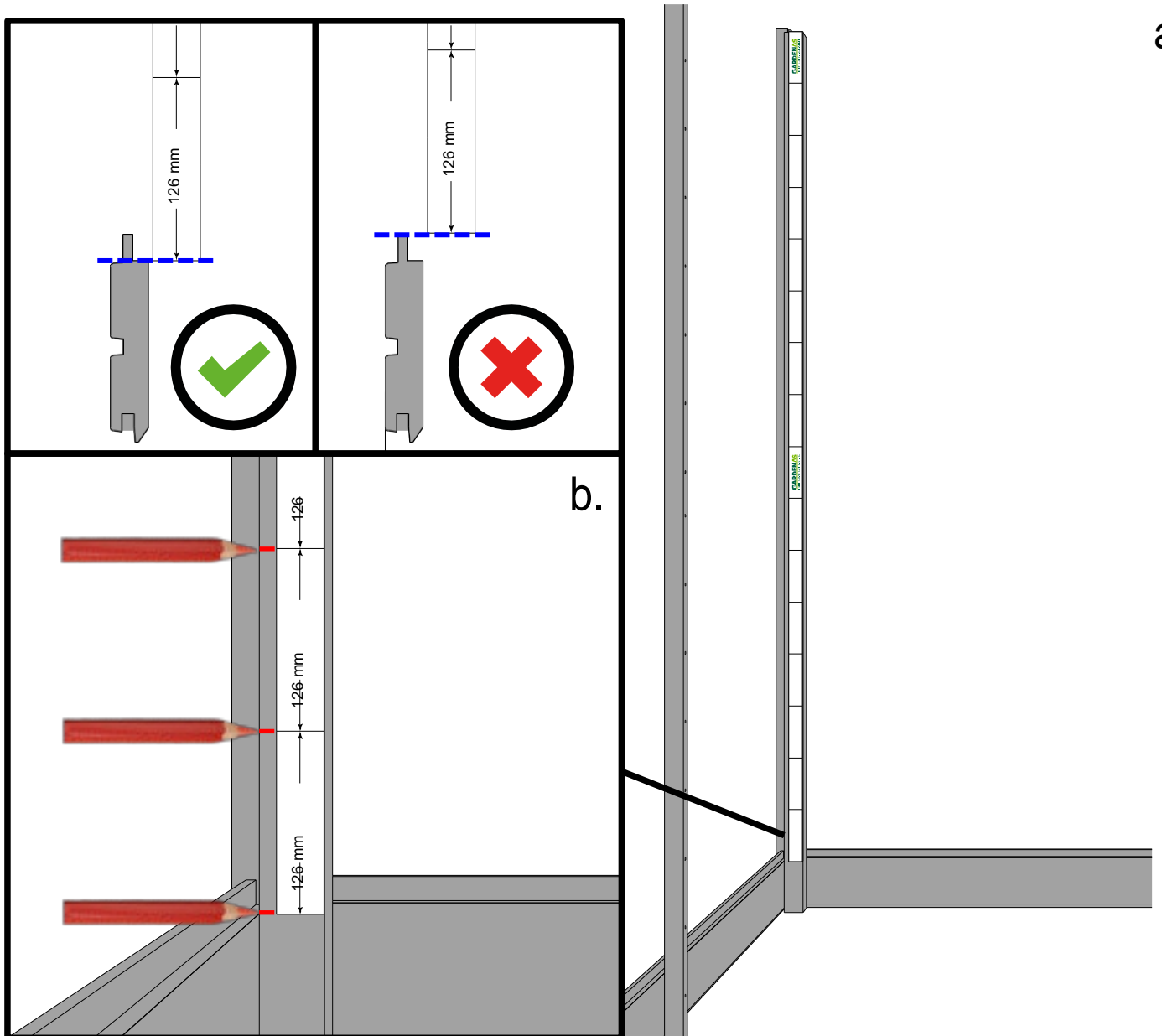

6.

### Applying silicone

Apply another bead of silicone to the corner profiles and door frame. Repeat on the other walls. Work with short strips of silicone based on your building progress.

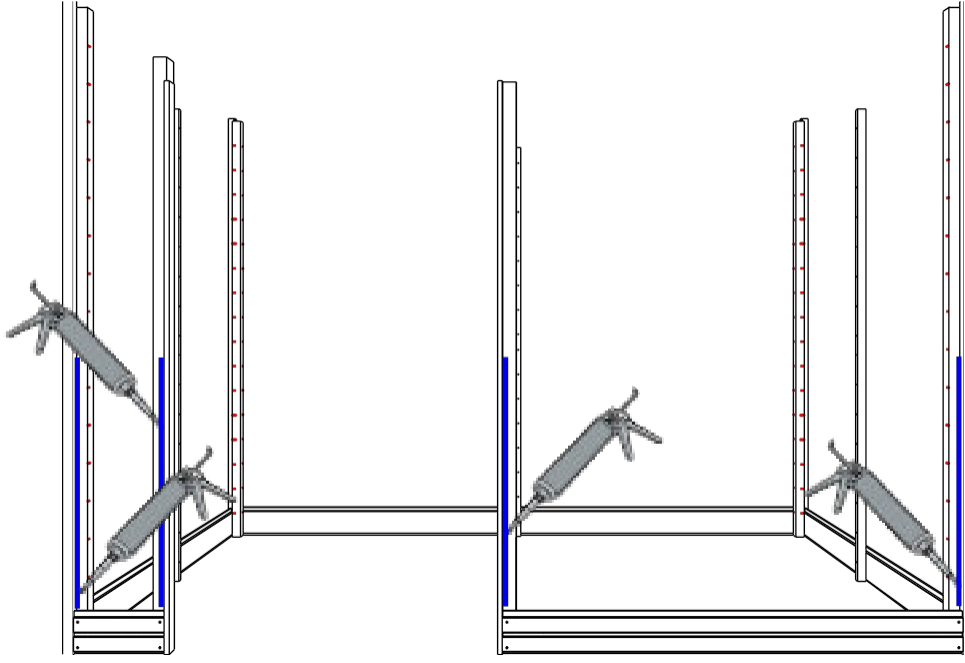

7.

### Securing the second layer of planks

Secure a second layer of planks against the profiles. Apply glue to the ends first!

**Attention!** The planks do not fully support each other! The flat side at the top of the plank must align with the mark you made earlier in step 5. Also secure them to the centre braces. Check that they are plumb.

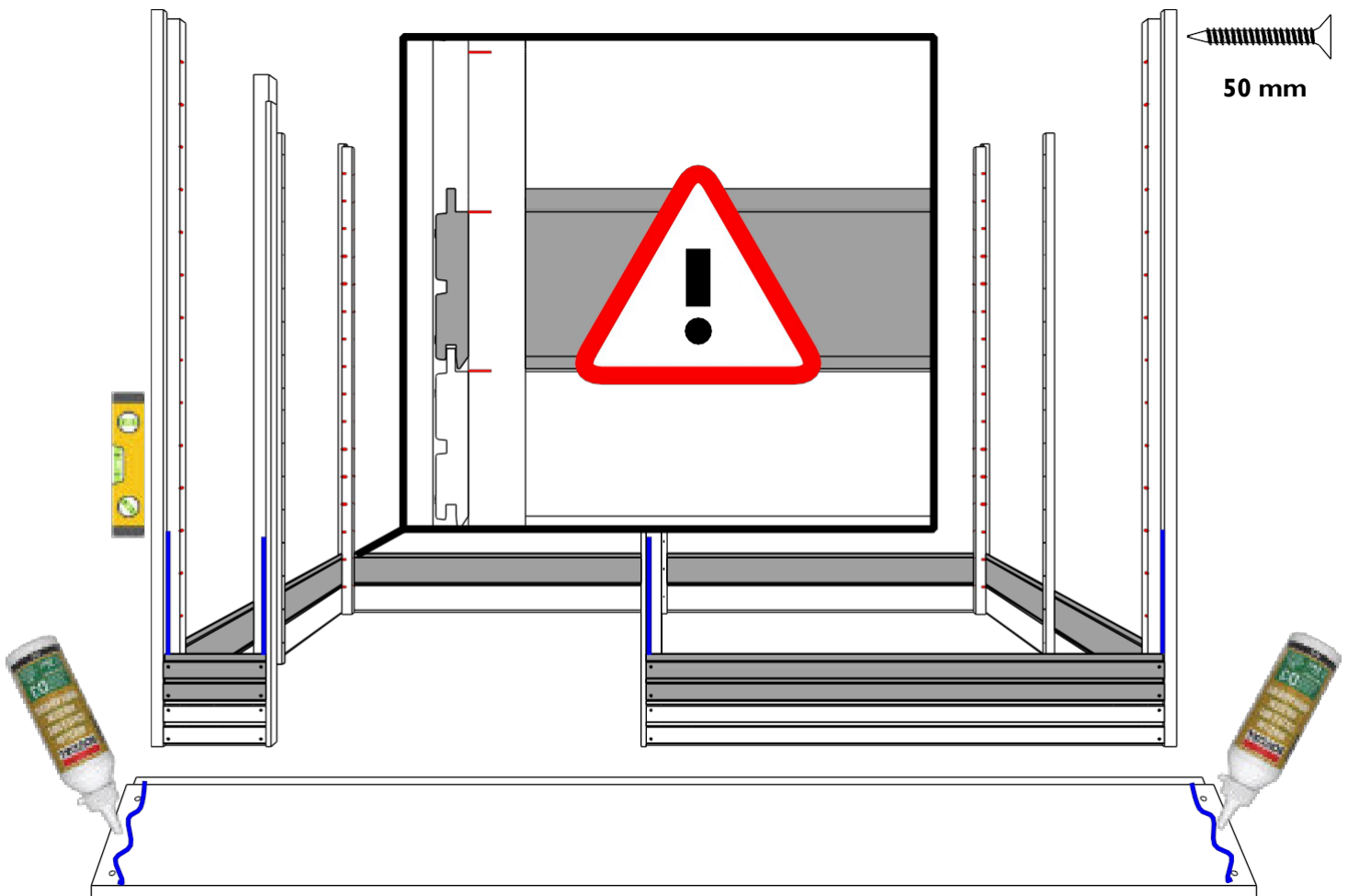

## 8. Securing the planks up to the window

Secure the planks to the profiles layer by layer, all the way round, until you have 12 layers.

**Attention!** The flat side at the top of the planks must always align with the mark.

Check regularly that the walls and the centre braces are plumb.

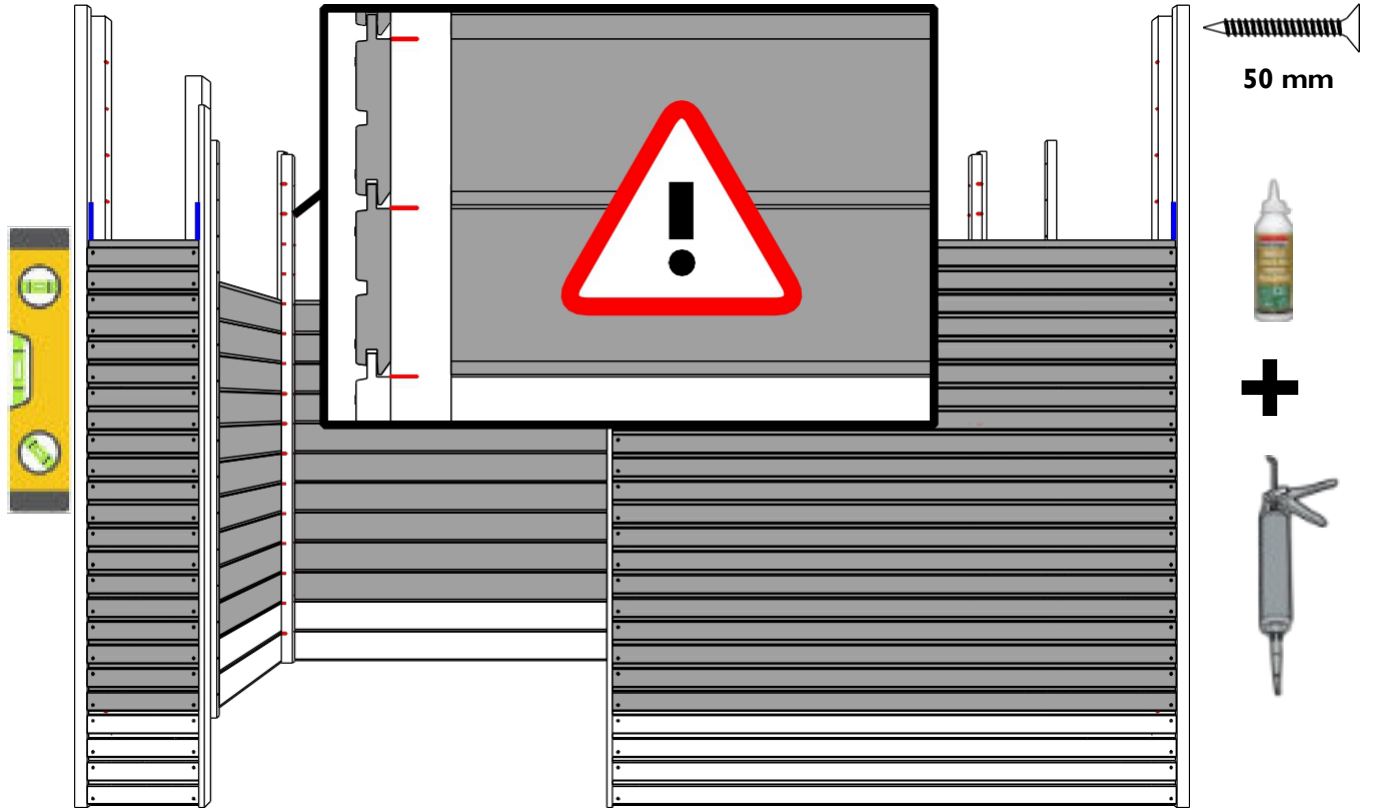

## 9. Mounting the window, part I

You can choose which side wall to place the window in.

Saw off the batten 599927, only in the wall where you are placing the window, flush with the tongue of the top plank.

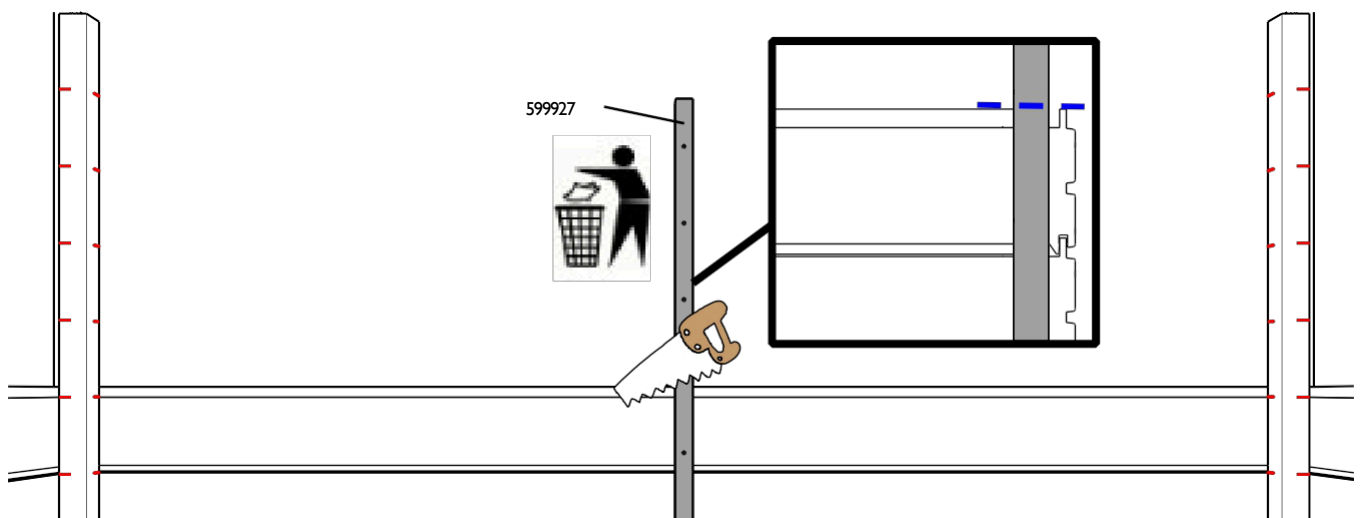

# 10.

## Mounting the window – Part 2

Place 1 piece QBH2/TG/1/FL on the left and 1 piece QBH2/TG/1/FR on the right.

a.

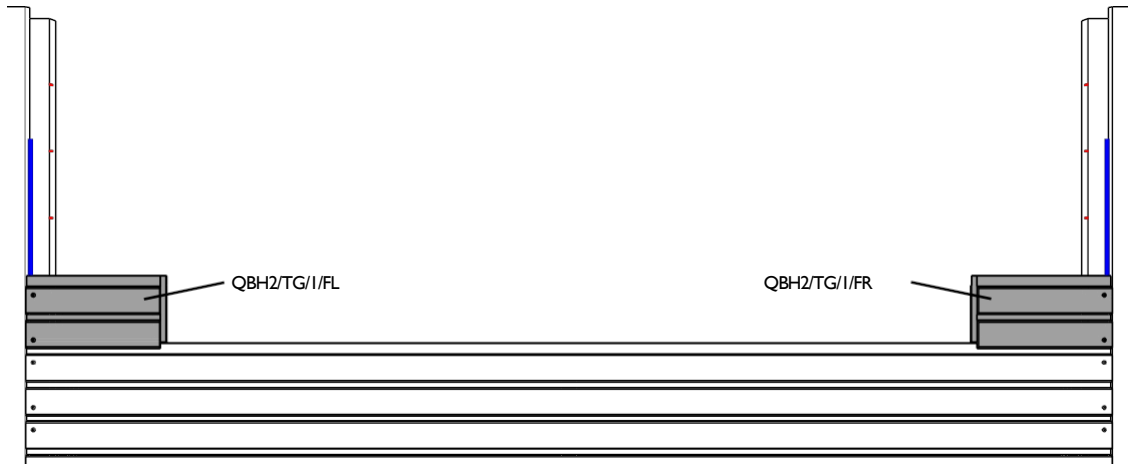

Apply glue in the window groove and position the window in the opening between the two short pieces.

b.

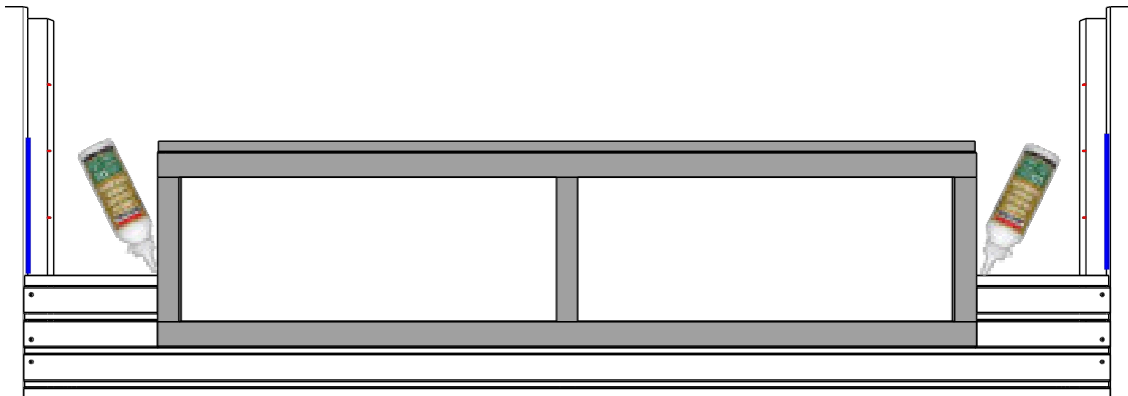

Secure the window from the inside by fitting the groove onto the tongue of the small pieces. Ensure that the bottom of the window aligns neatly with the line of the small pieces. Do not forget to pre-drill here!

c.

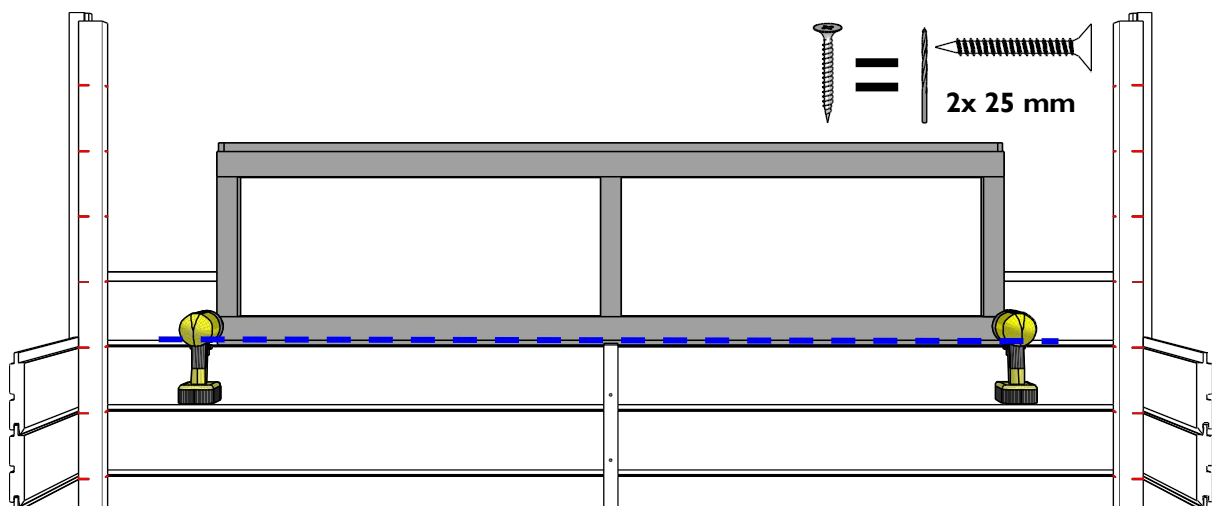

Place the remaining small pieces on the left and right.

d.

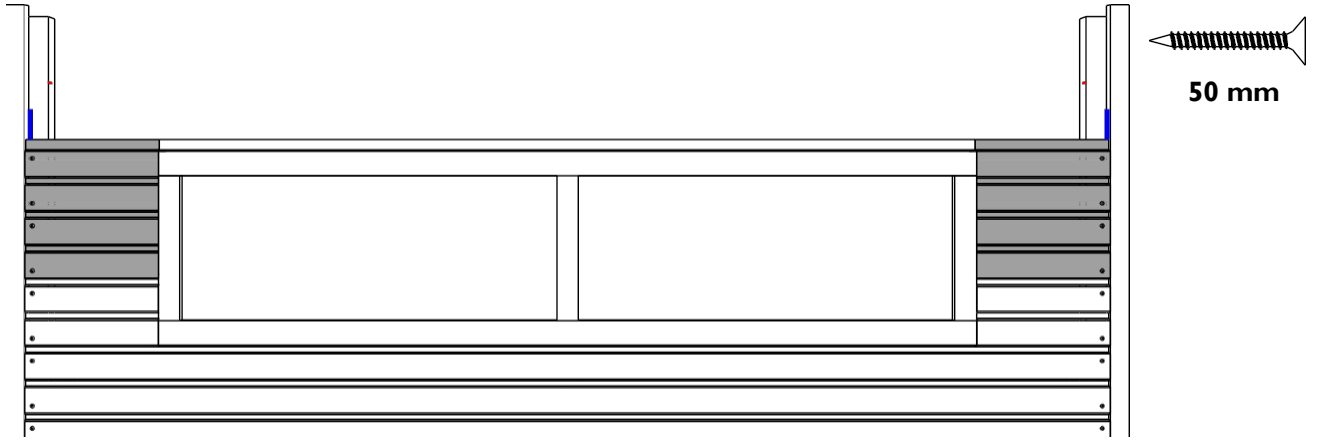

Secure the window from the inside by inserting the groove onto the tongue of the top small pieces. Don't forget to pre-drill!

e.

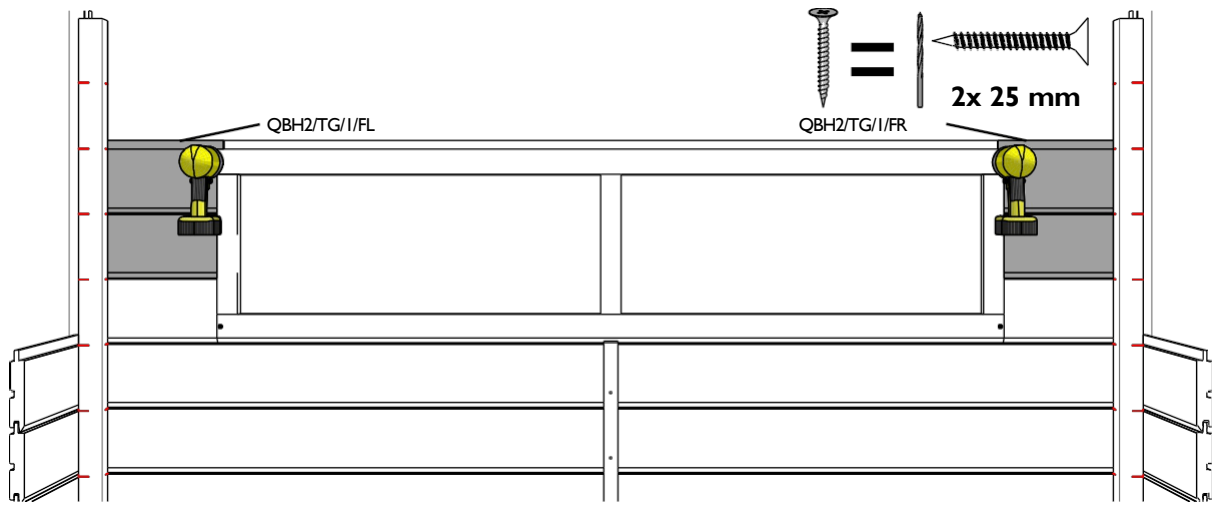

II.

### Remaining planks

Secure the remaining planks. The top layer consists of QBH2/PLK planks, with a thick tongue.

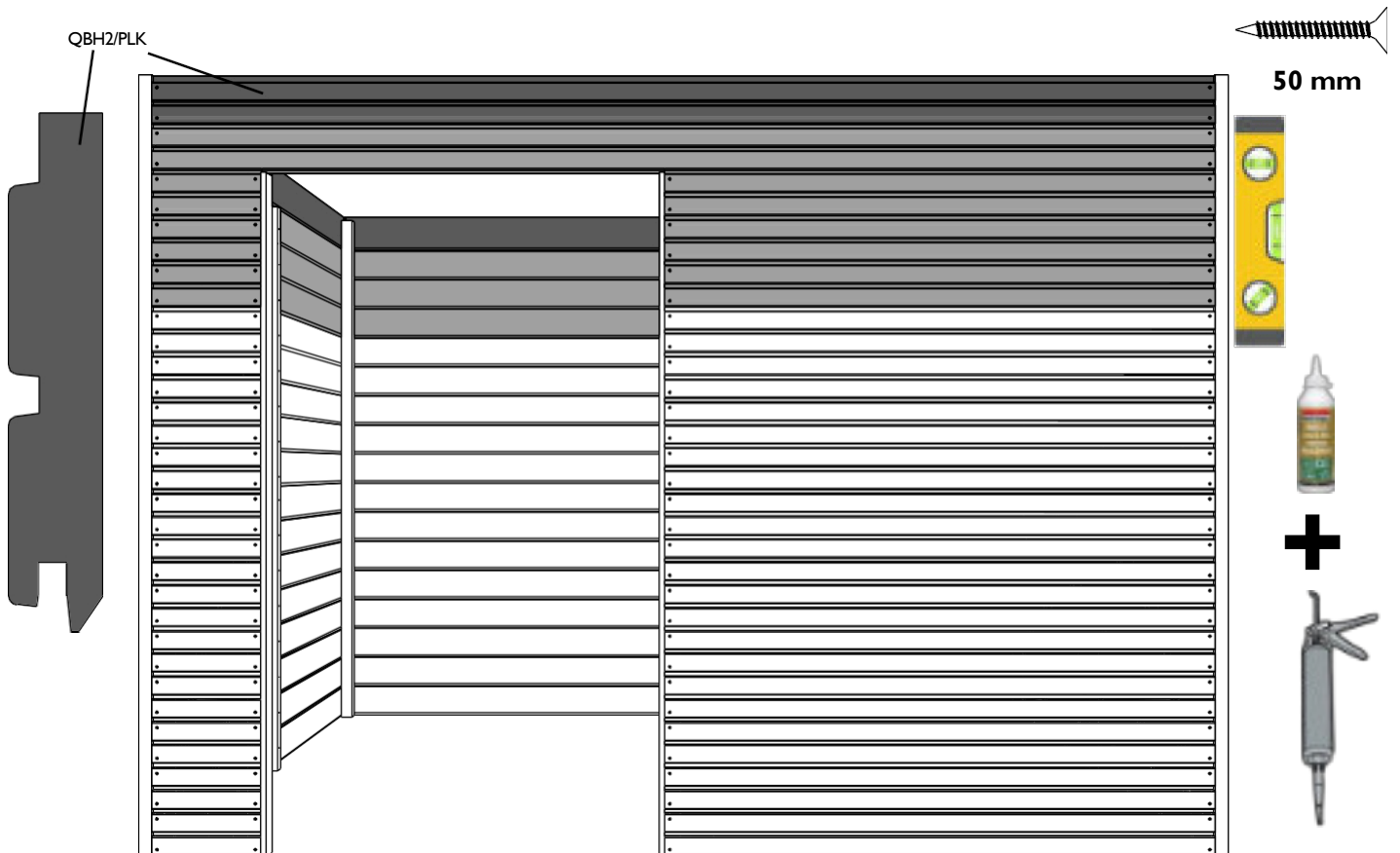



Mounting the extension. You can mount it on either the left or the right.  
 The drawings show installation **on the left**. Mirror the drawing for installation **on the right**.  
 Any second extension is mounted only after the garden shed roof is installed; see step 31.

# 12.

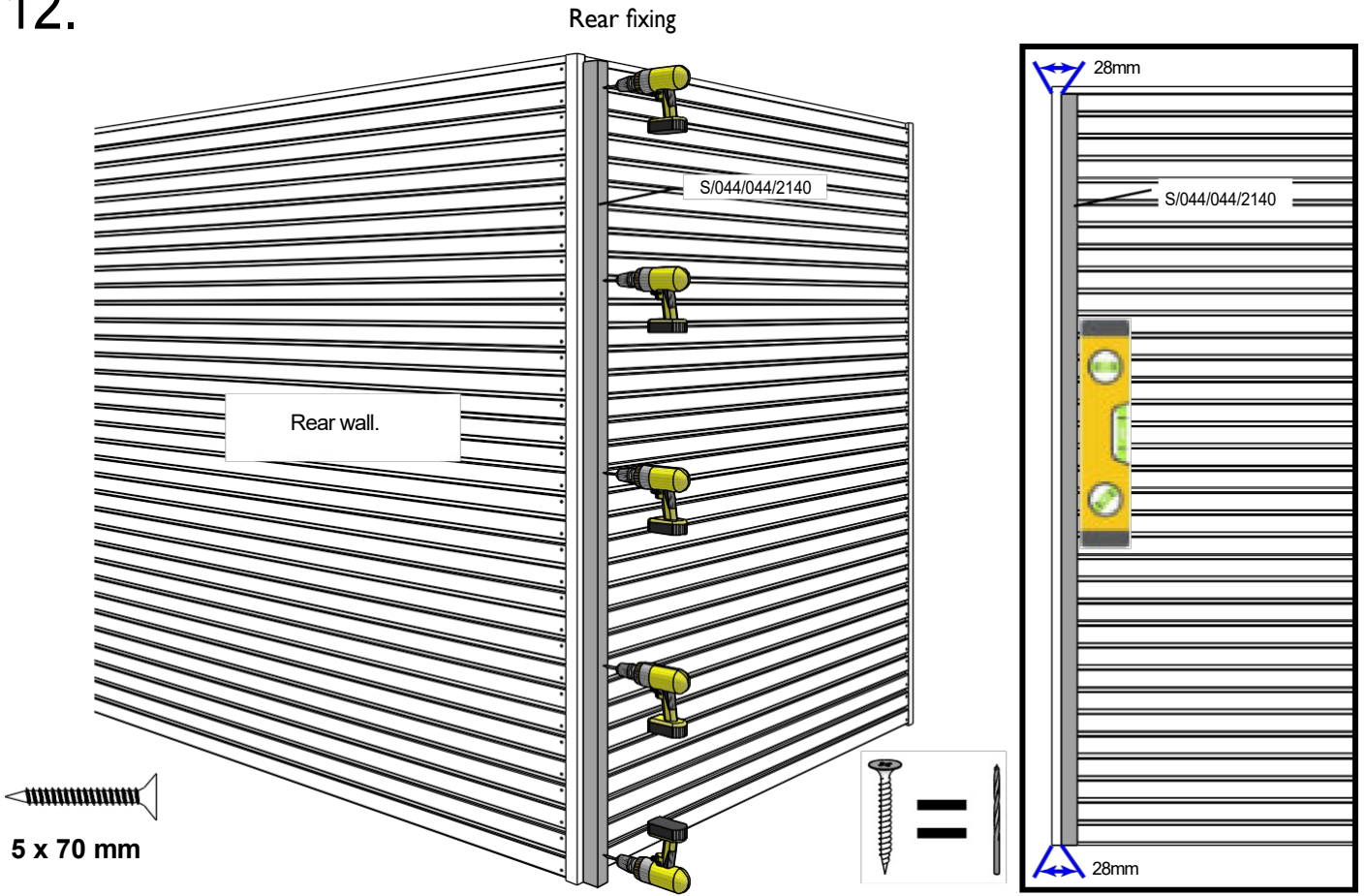

# 13.

Fit the first rear wall plank (**outside**) and mark the positions (see also step 5)

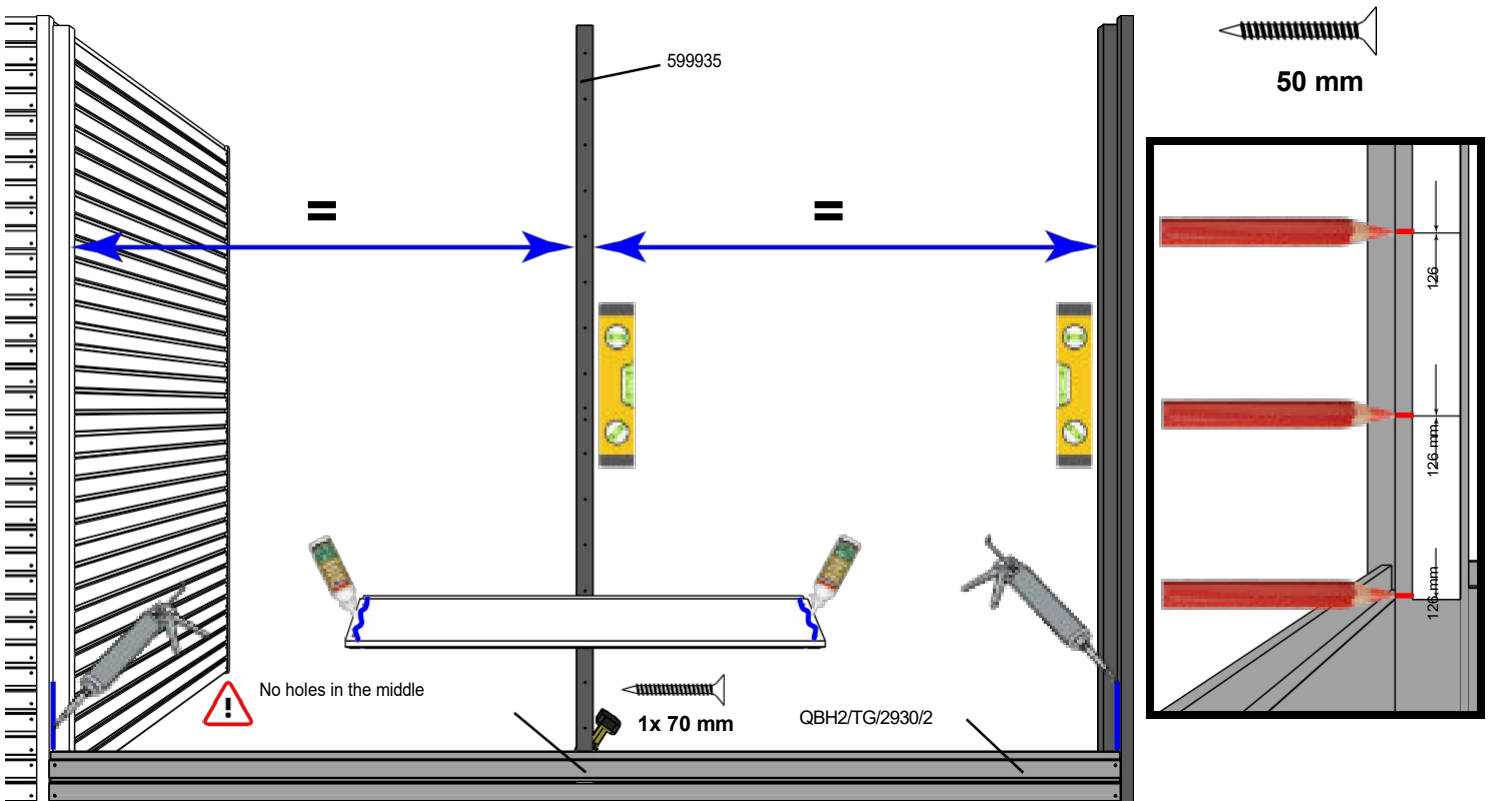

14.

Trim batten on the side and first rear wall plank (inside)

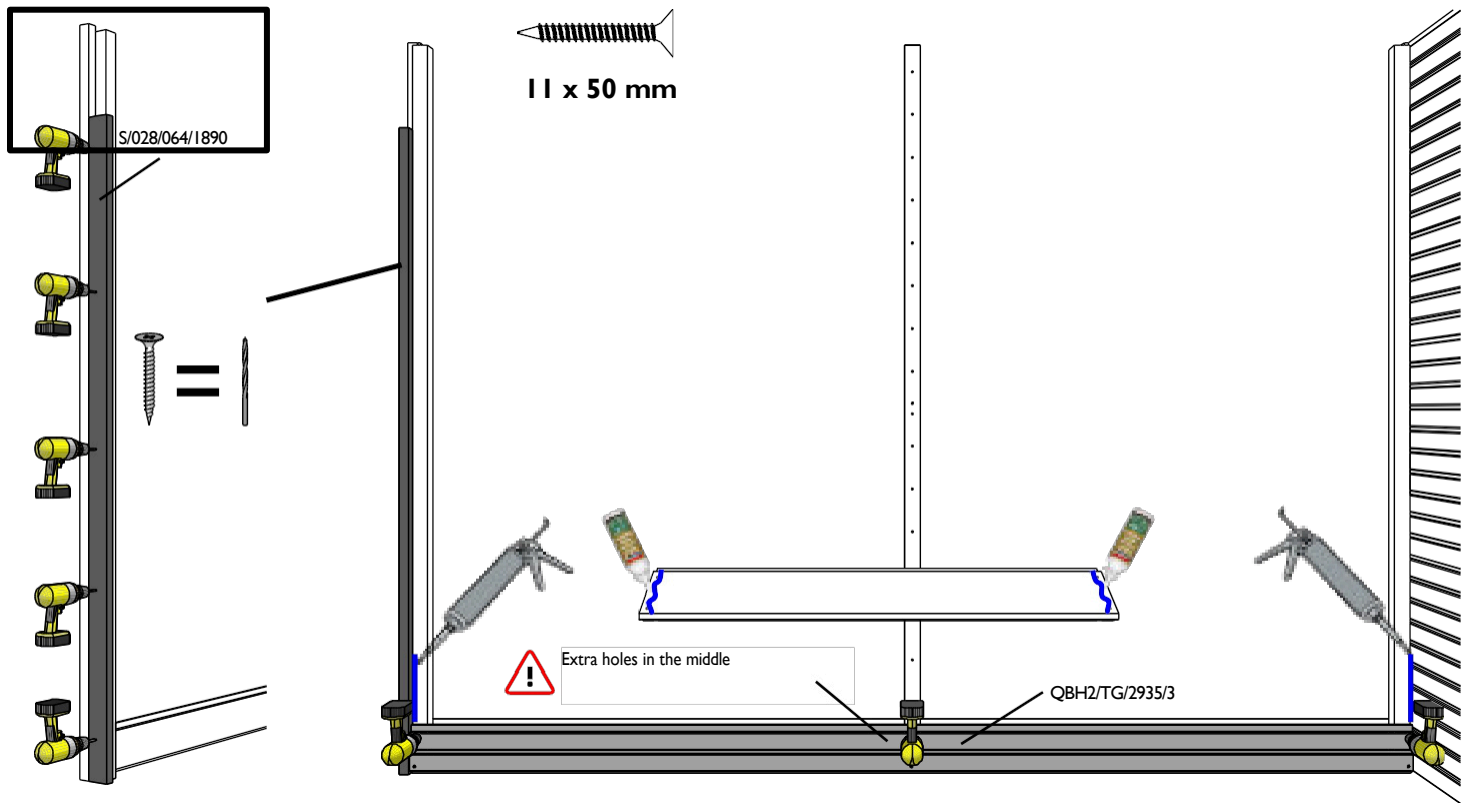

15.

Alternately secure one plank on the **outside** and **then** one plank on the **inside**.  
Do not mount the top planks yet.

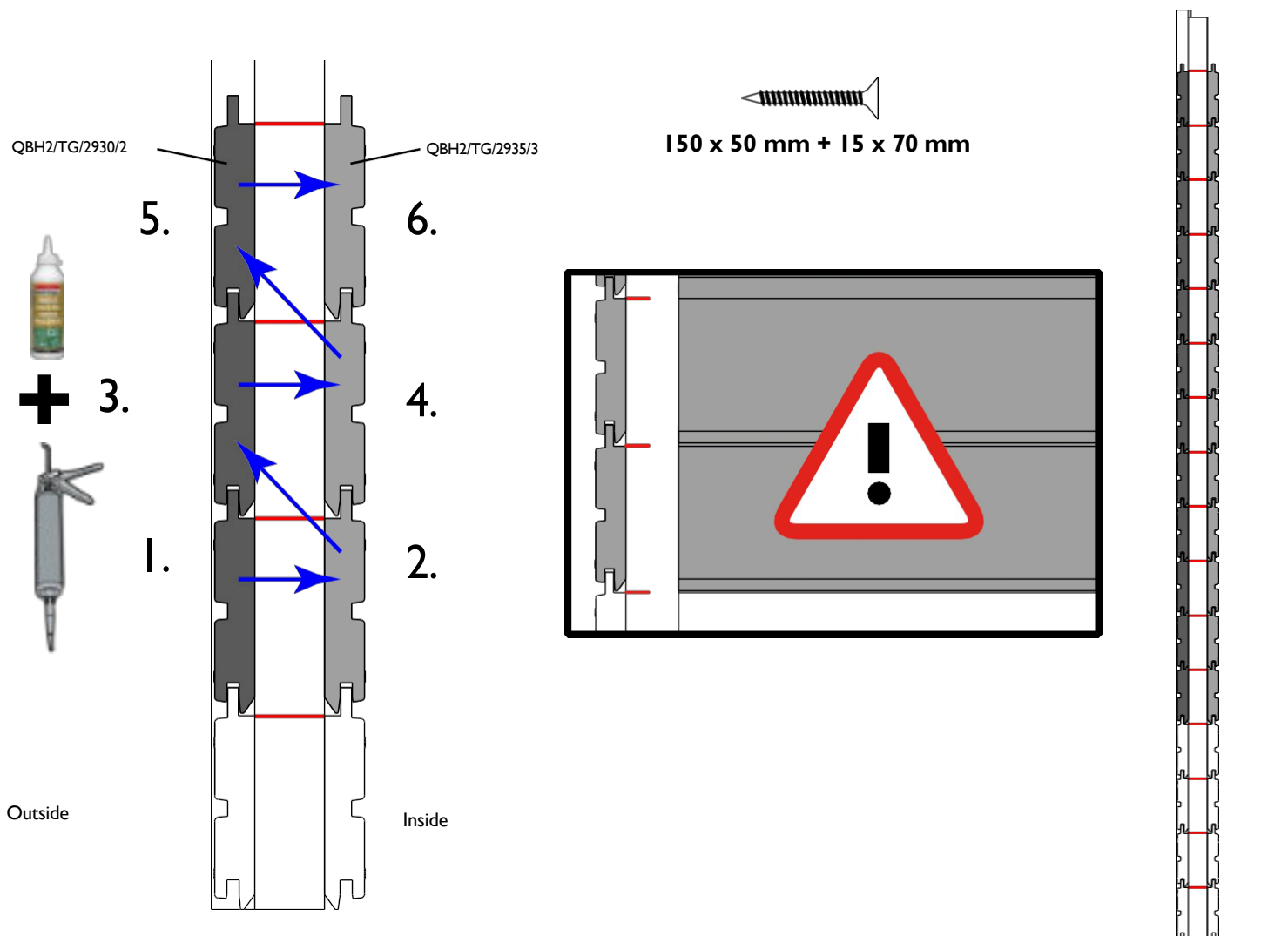

16.

Top plank, outer wall



17.

Preparation for top plank, inner wall.



Extension on **the left!**

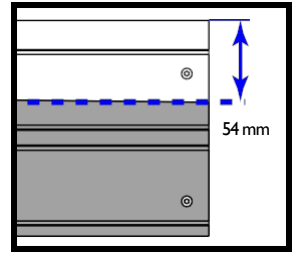
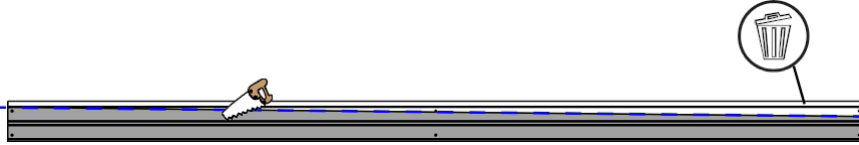
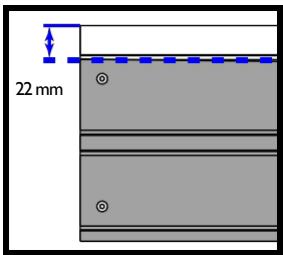

Extension on **the right!**

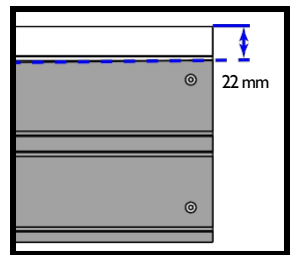
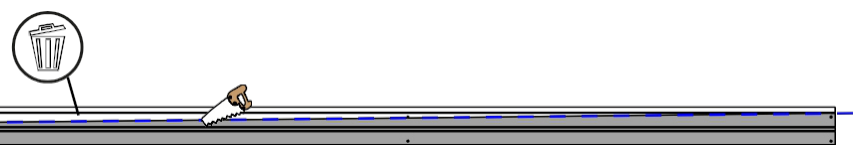
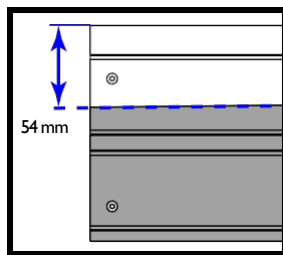

18.

Securing the top plank on the inner wall.

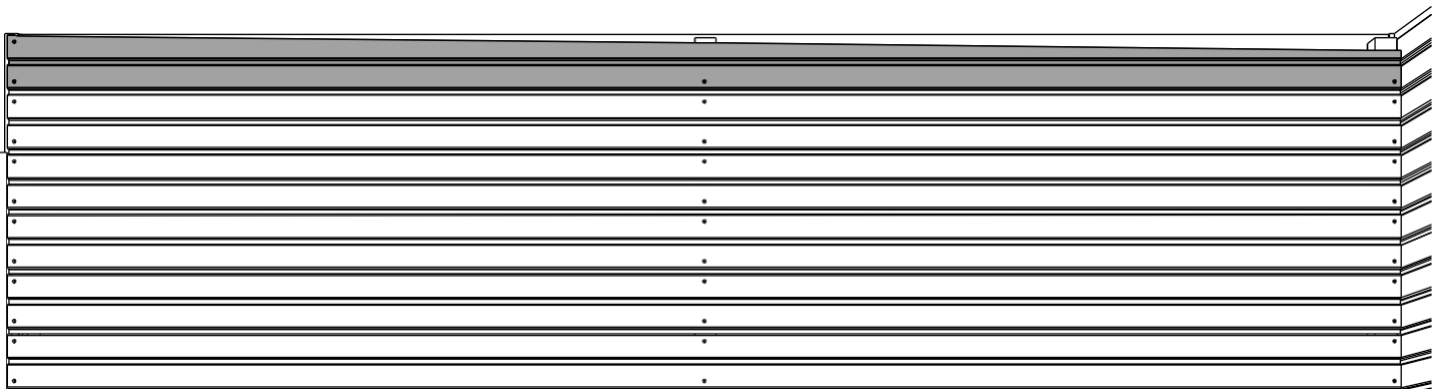
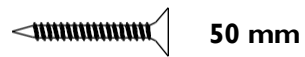

19.

Cutting the slope side of the garden shed (extension side).

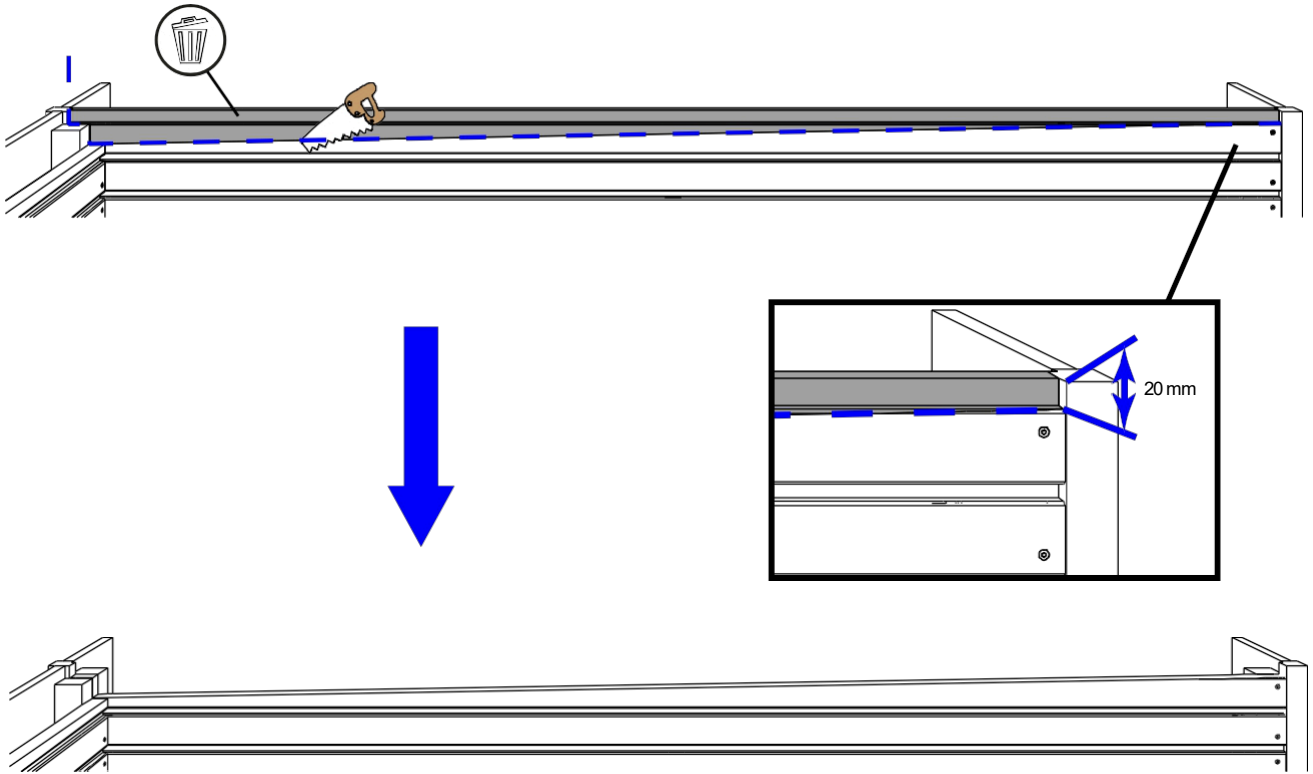

20.

Securing joist hangers

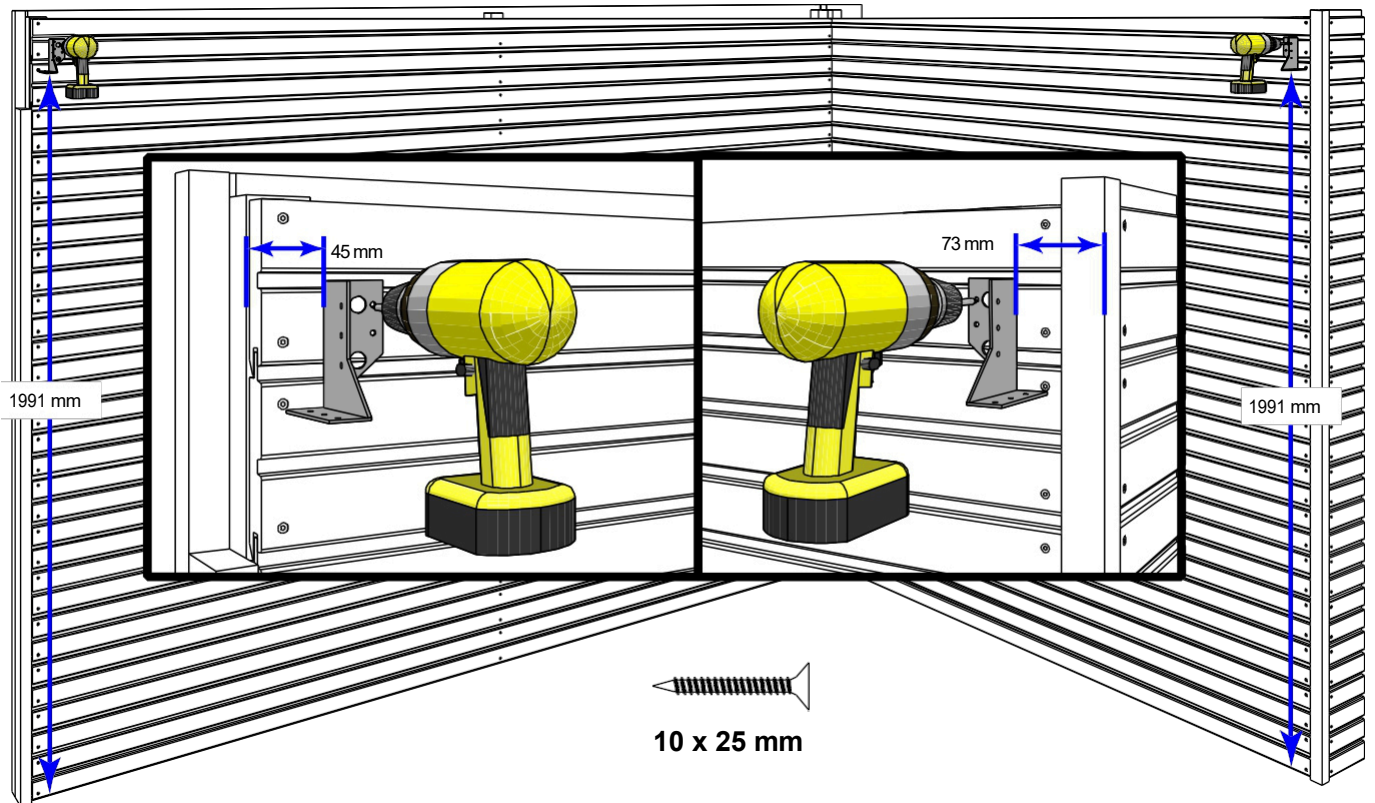

21.

Installation of the post and beams

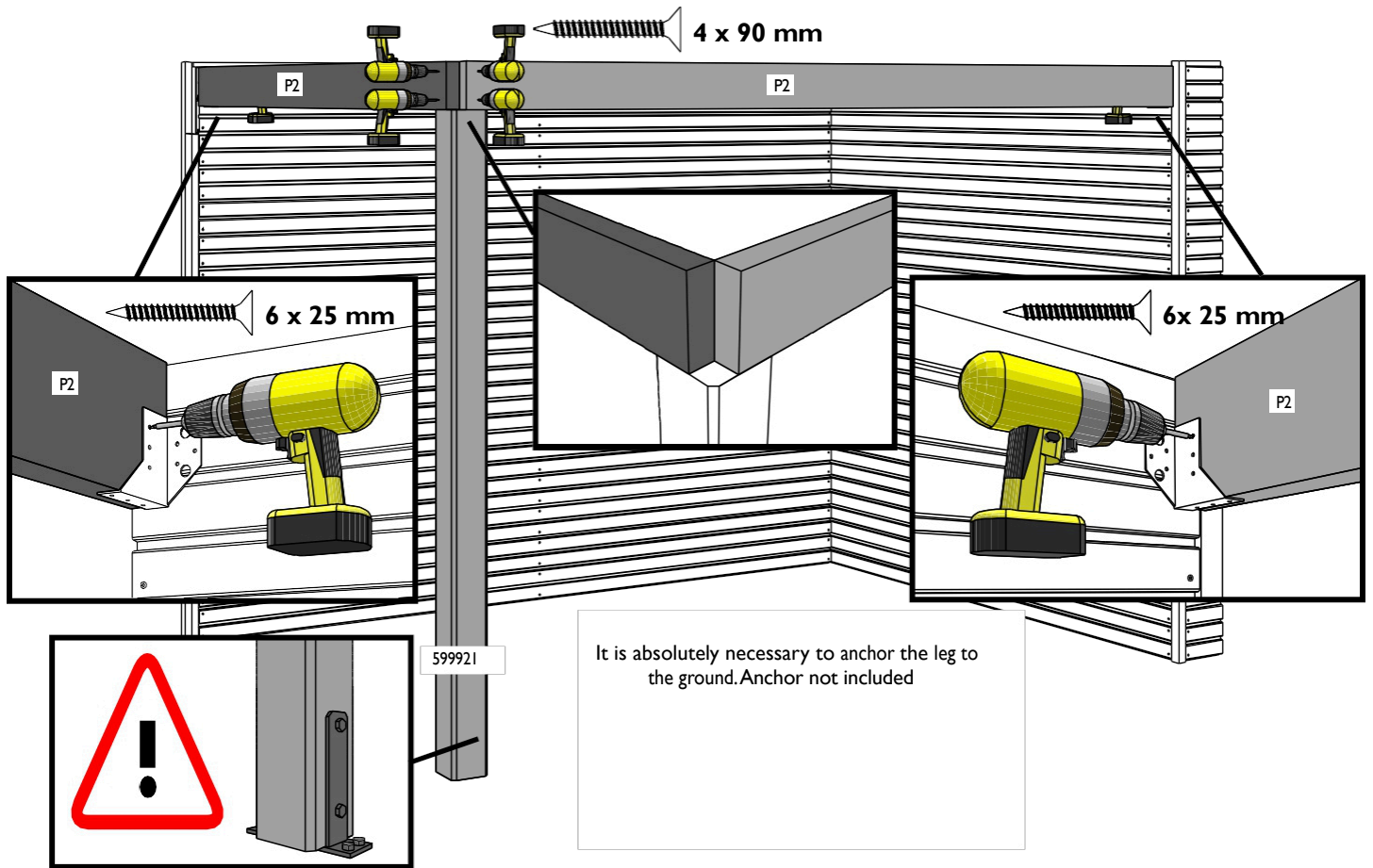

22.

Preparation for covering the beams

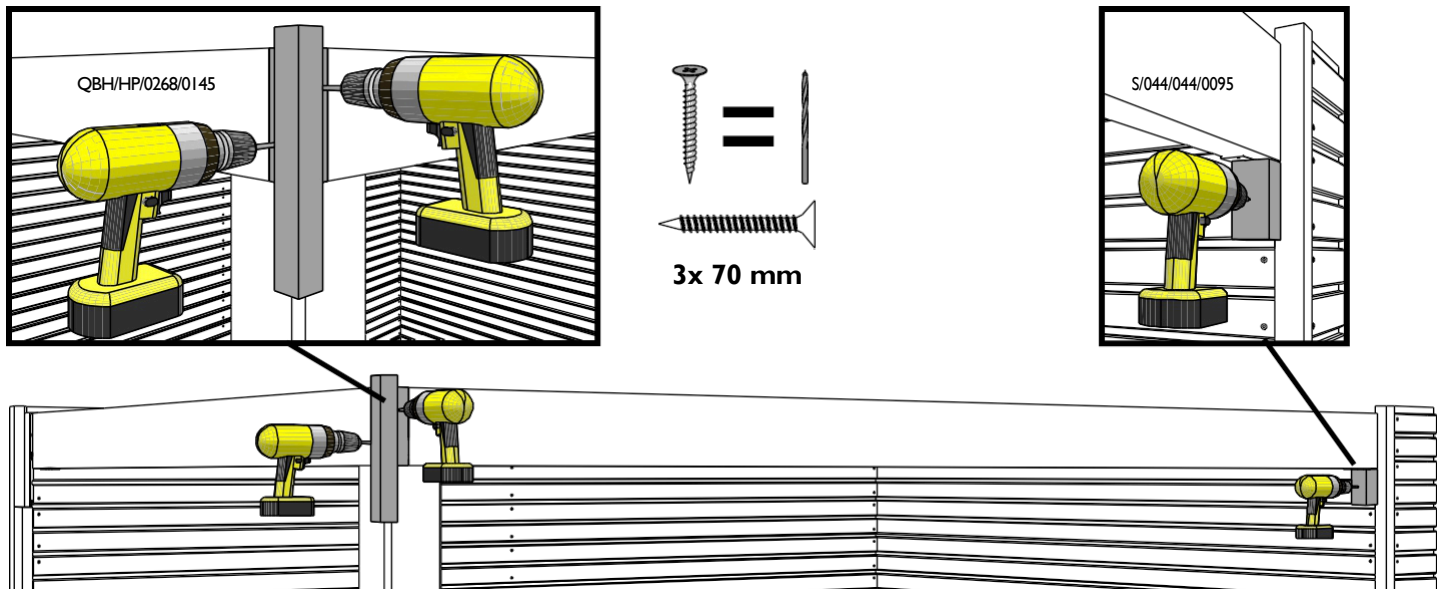

23.

Covering the beams

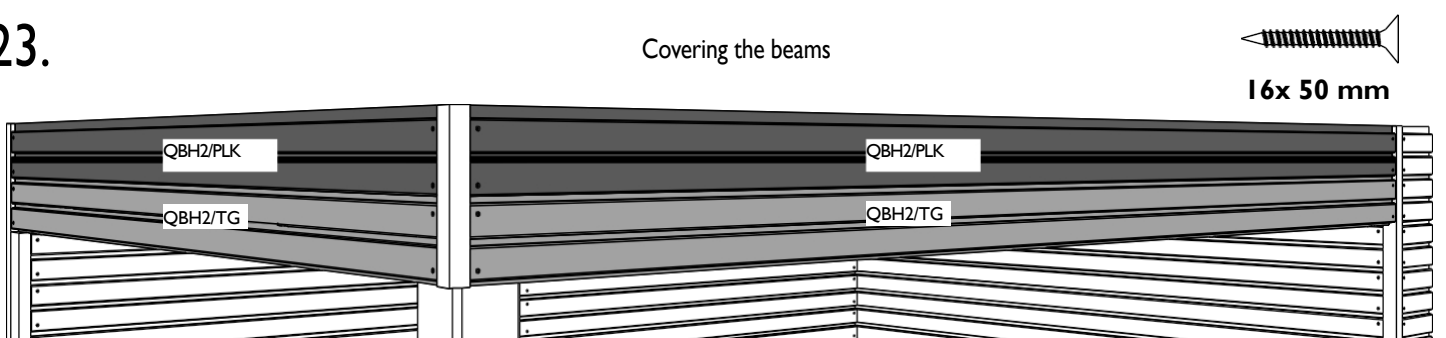

24.

### Mounting of the roof support structure

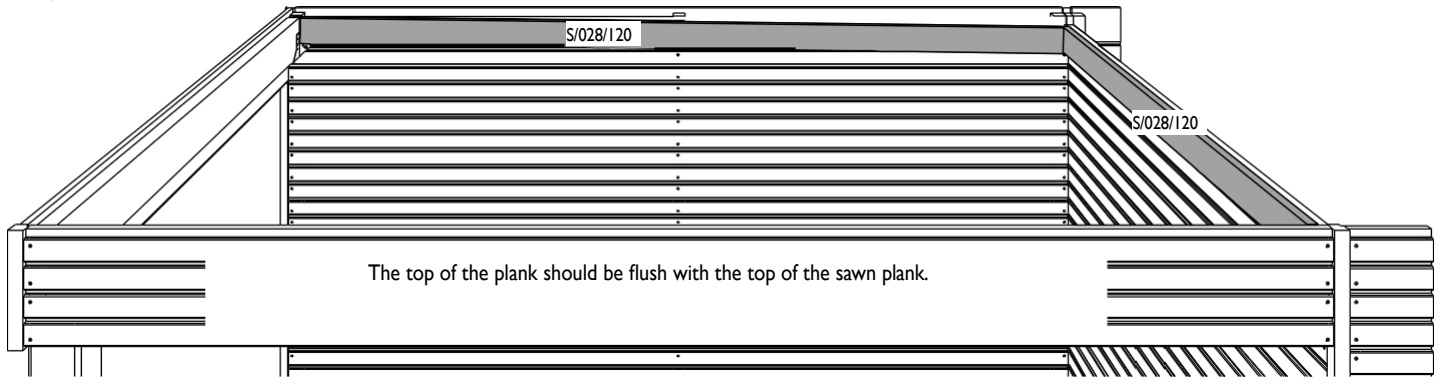

**Place at least 2 screws every 40 cm!**

Rear

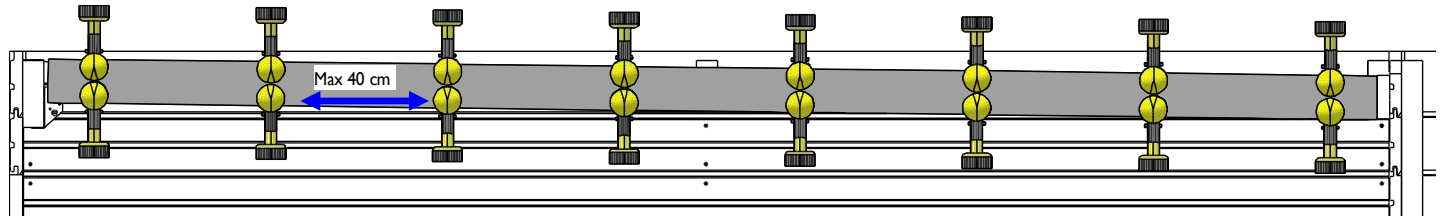

Side wall of the garden shed

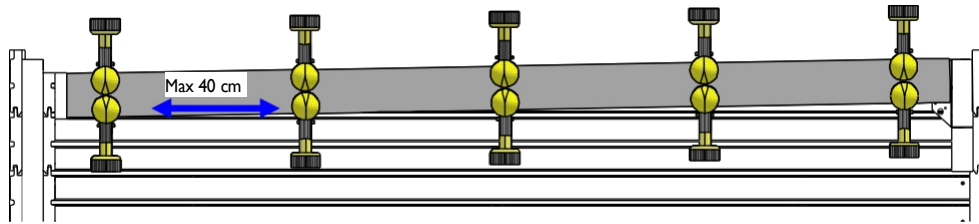

25.

### Preparation of the rafters

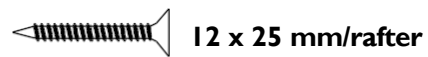
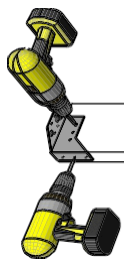

S/028/120

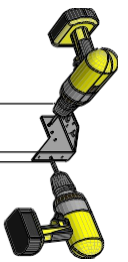

26.

### Installation of the rafters

Distribute the rafters symmetrically across the width of the garden shed.

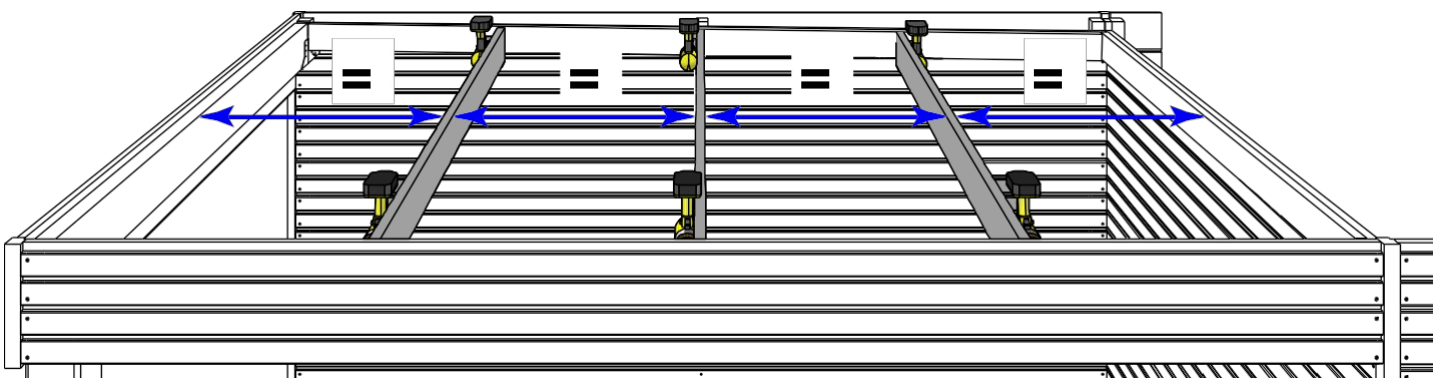
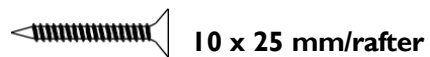



It is **VERY** important to follow the instructions carefully.  
The entire weight of the roof is supported by these 4 planks.

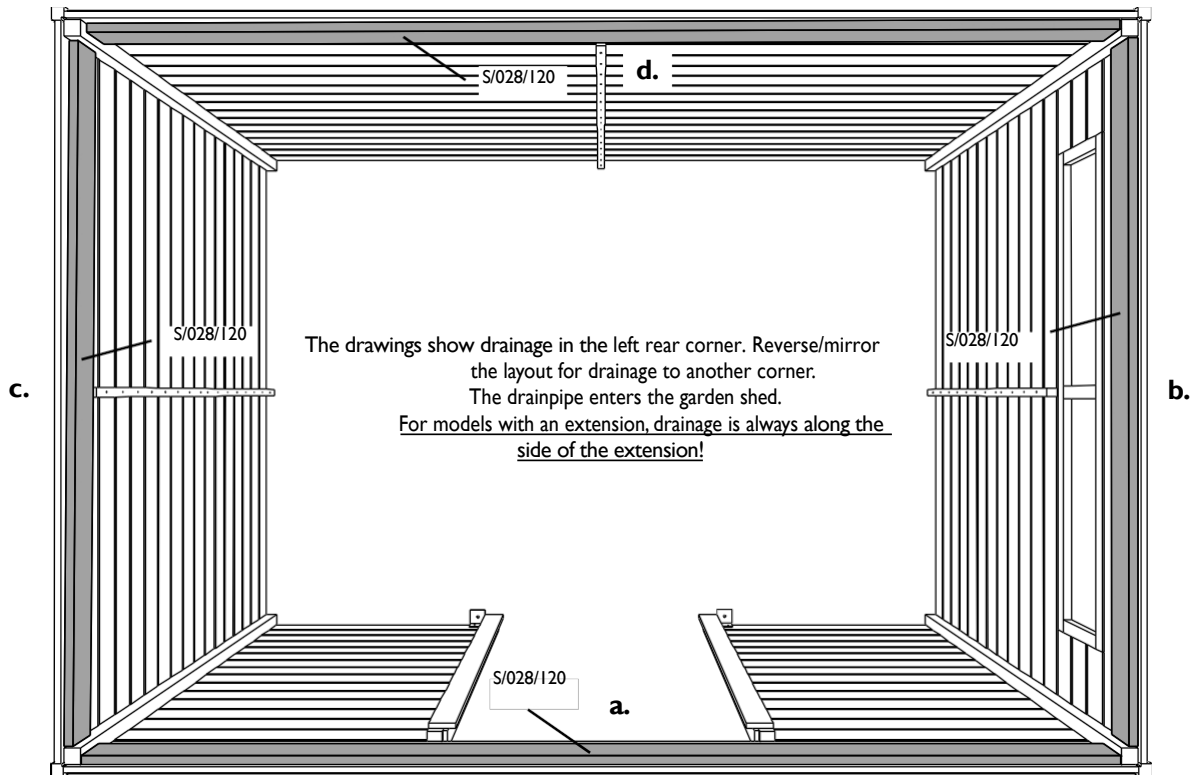

**Place 2 screws at least every 40 cm!**

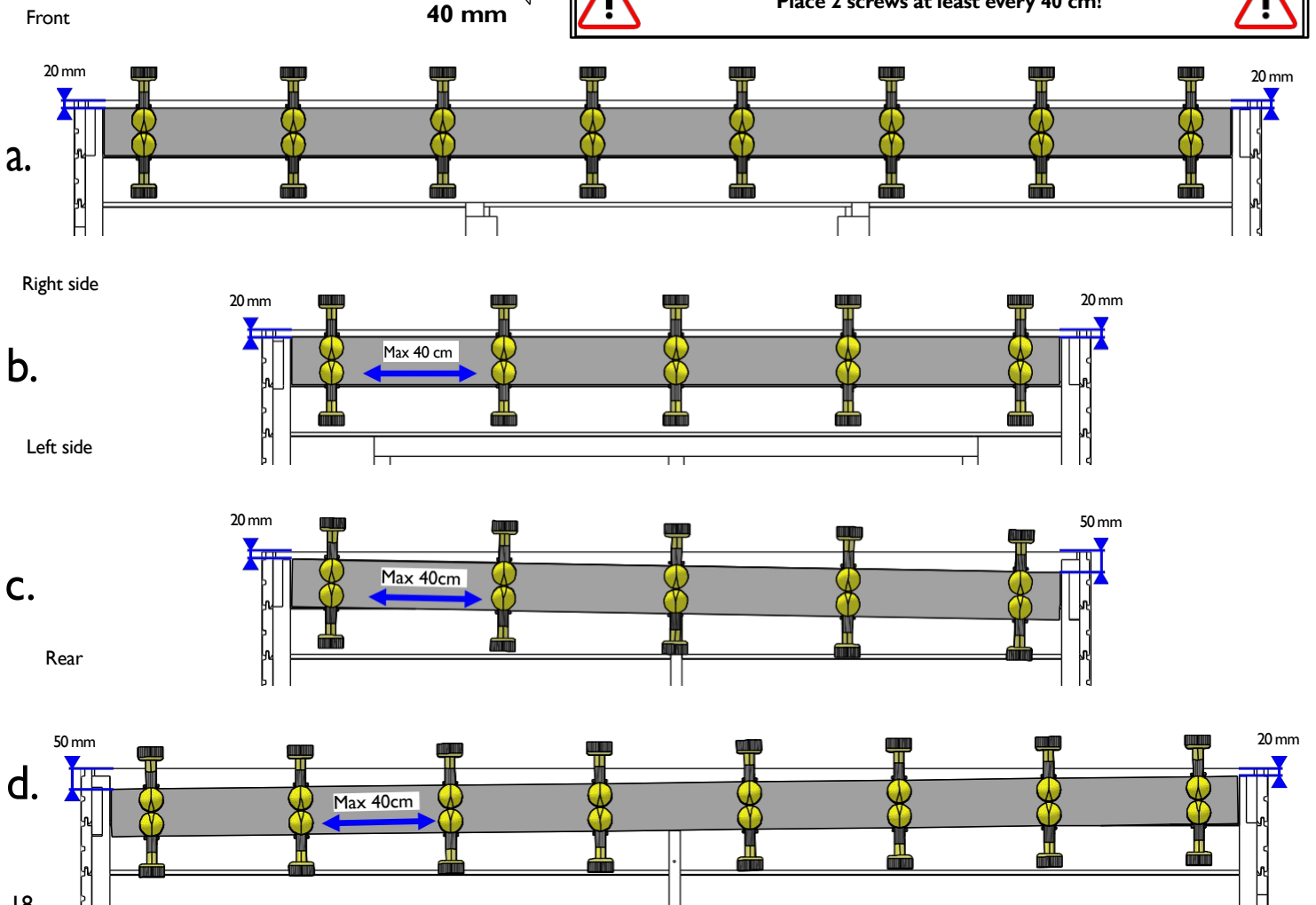

28.

Preparation of the rafters

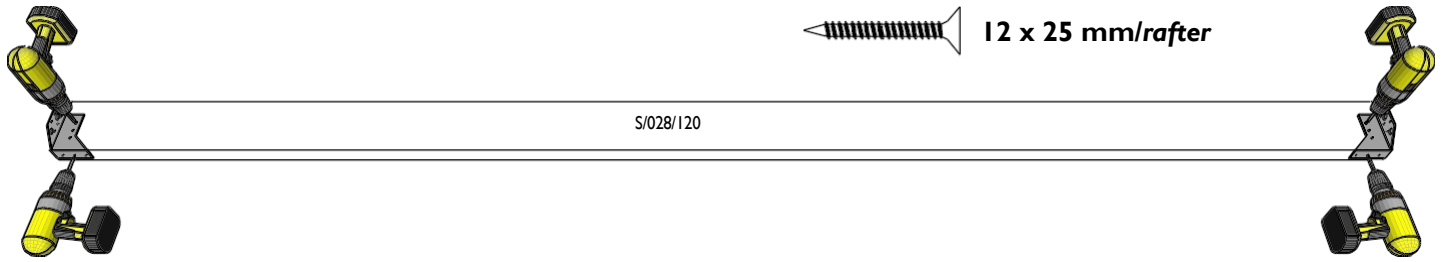

29.

Installation of the garden shed rafters

Distribute the rafters symmetrically across the width of the garden shed.  
The number of rafters may differ from the shed you have purchased.

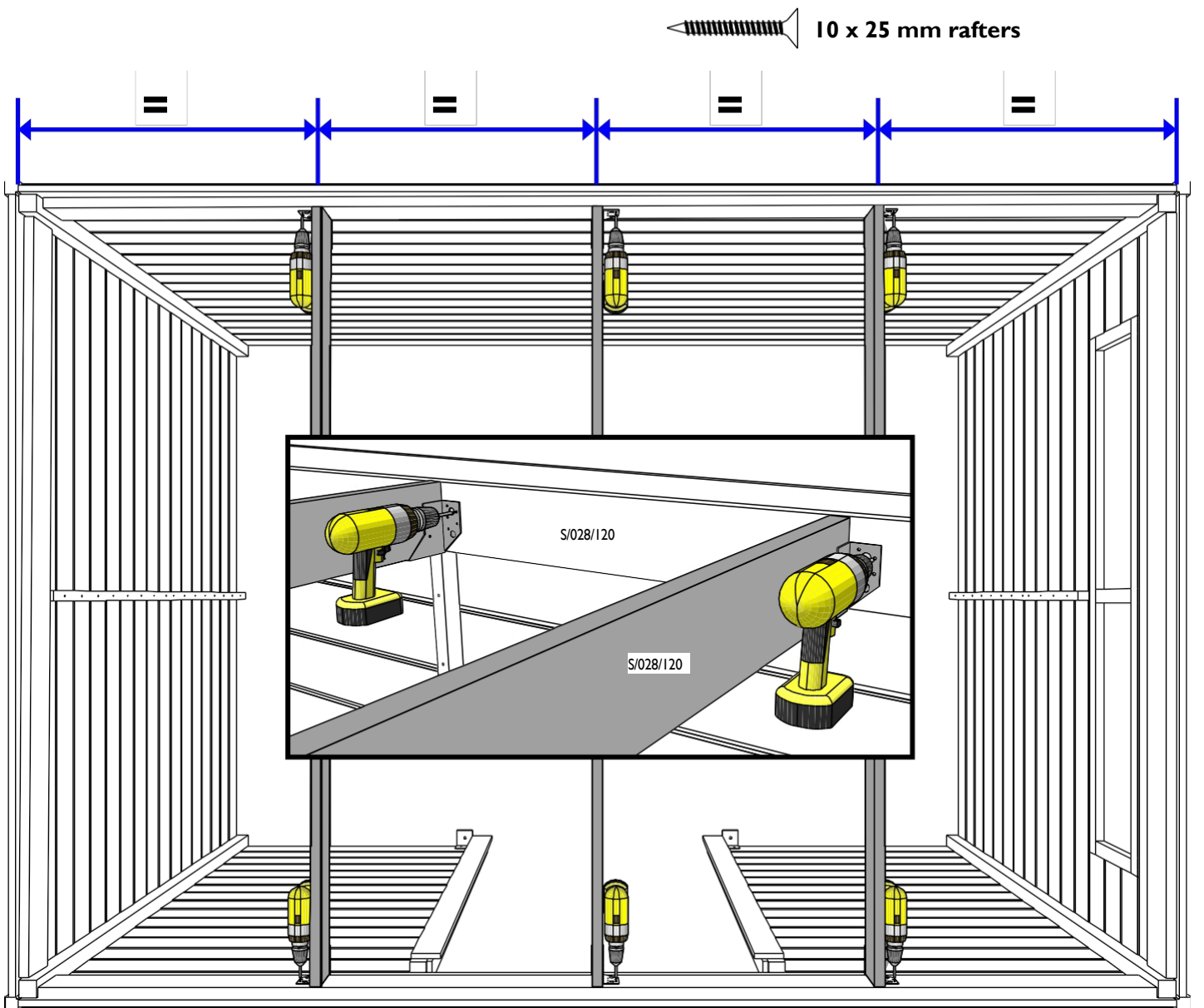

Refer to the diagrams in the parts list for the installation of the sheets; always start in the front left corner. Allow a 5 mm expansion gap between the OSB and the walls.  
For models with an extension, the OSB continues across both roof sections.

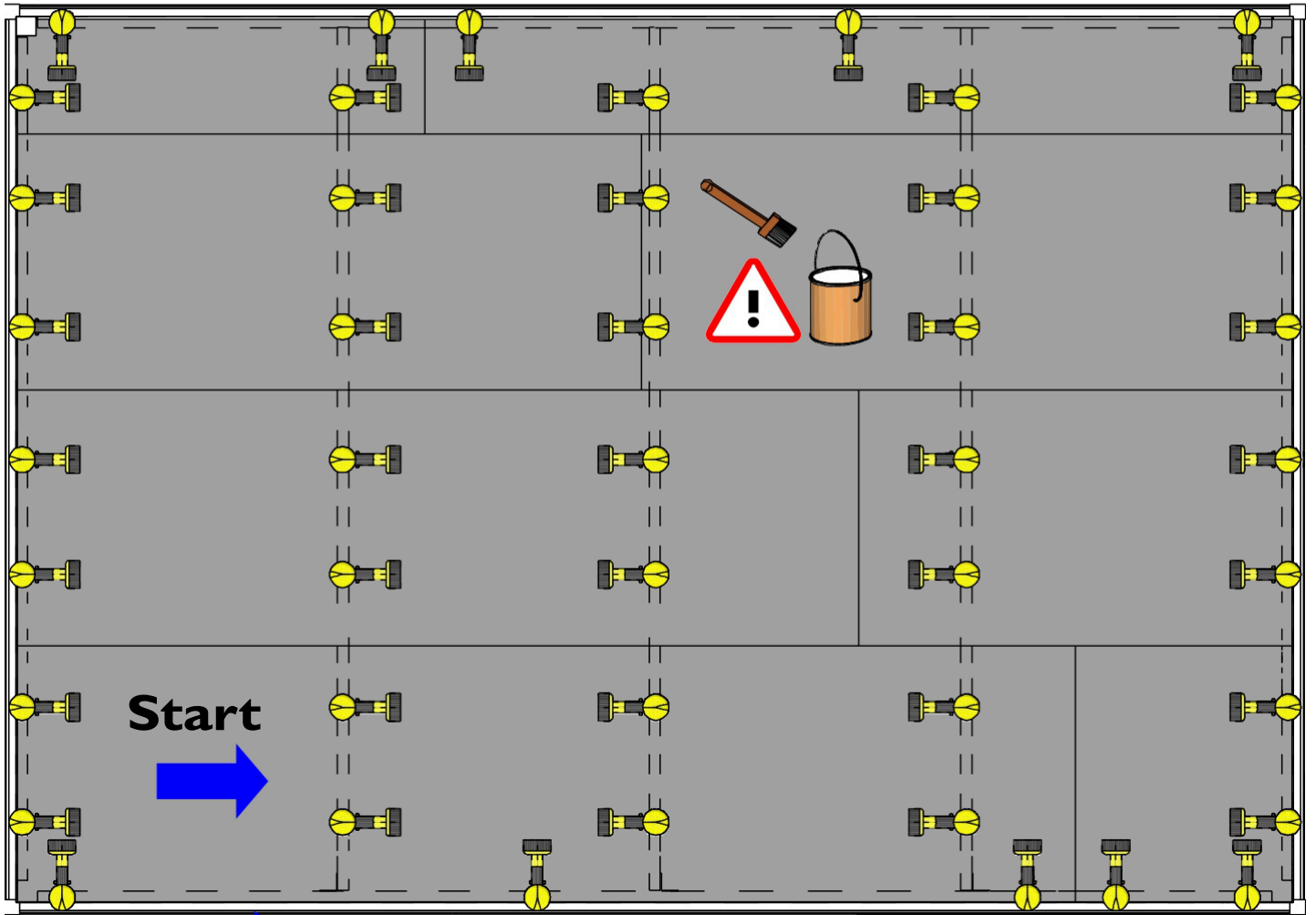
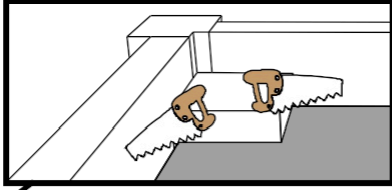

5 mm expansion gap all round



Treat the OSB3 roof sheets on top and bottom with a protective coat of stain or other paint; this will significantly extend the lifespan of your product and help prevent mould.





**ATTENTION!** The following instructions explain how to install a second extension.  
Go to step **36** for the instructions without an extra extension.



You can install this extra extension either to the already placed extension or to the other side of the garden shed.

The drawings show installation on the already placed extension **on the left**. Reverse/Mirror the drawing for installation **on the right**.

31.

Securing at the rear

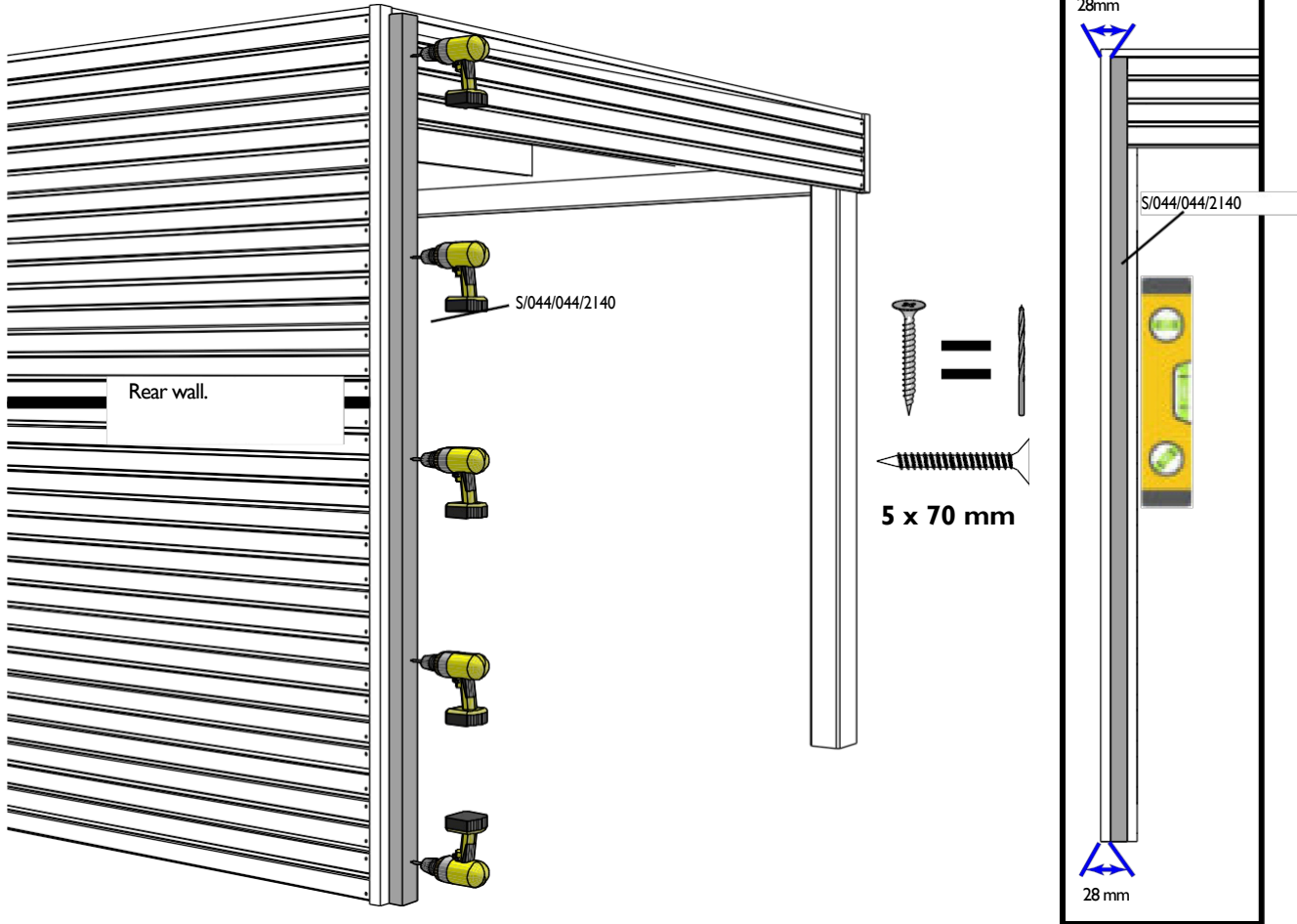

32.

Build the rear wall as described for the first extension, steps 13–18.



**ATTENTION!** Do not saw as described in step 19!



33.

Continue building as described for the first extension, steps 20–23.

34.

Mounting of the roof support structure

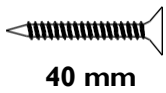
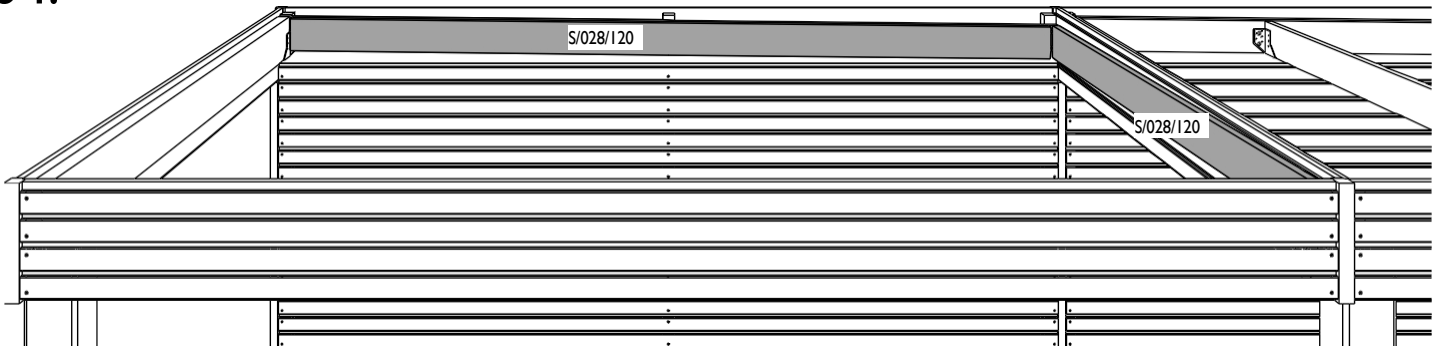

40 mm



The top of the plank should be flush with the top of the sawn plank.

Rear

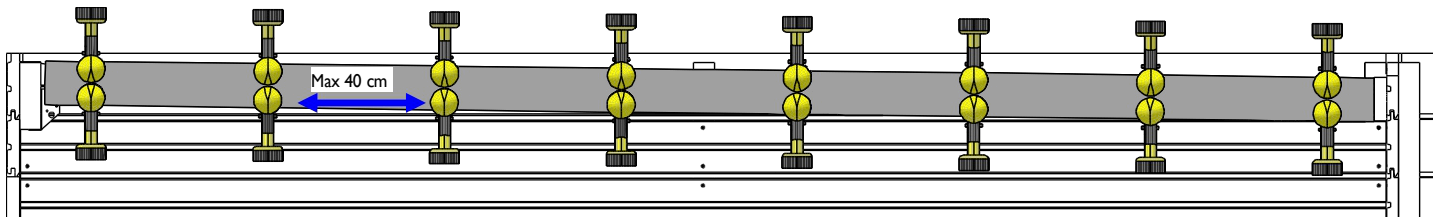

Side wall of 1st extension / garden shed

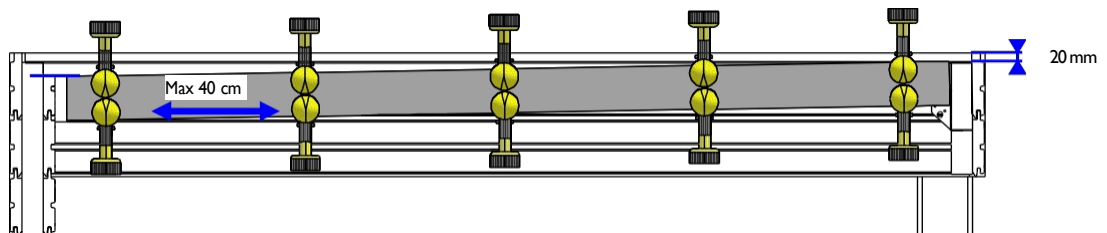

35.

Finally, mount the rafters; see steps 25–26.  
Place the OSB, see step 30.

# 36.

## Mounting the gutter

a1. Garden shed without extension

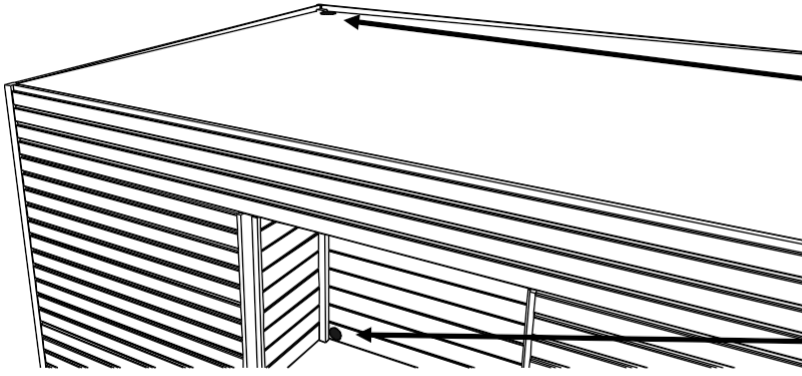

Place the gutter at the lowest point of the roof. See also step 27.

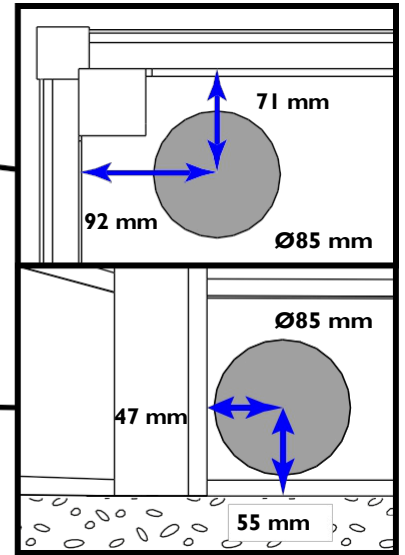

a2. Garden shed with extension

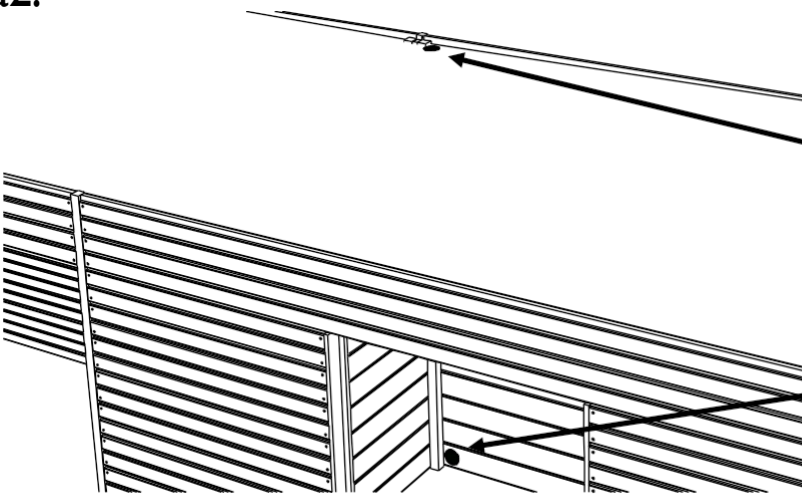

place the gutter at the lowest point of the roof. See also step 27.

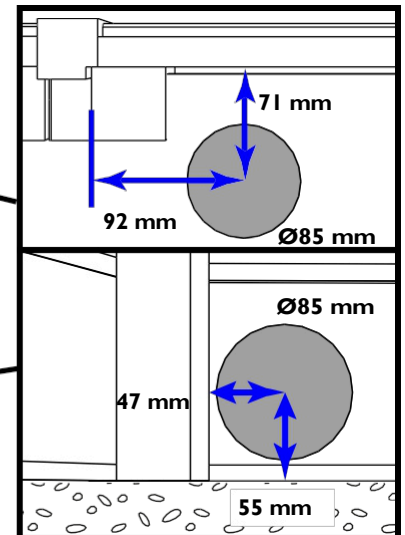

a3. 2nd extension

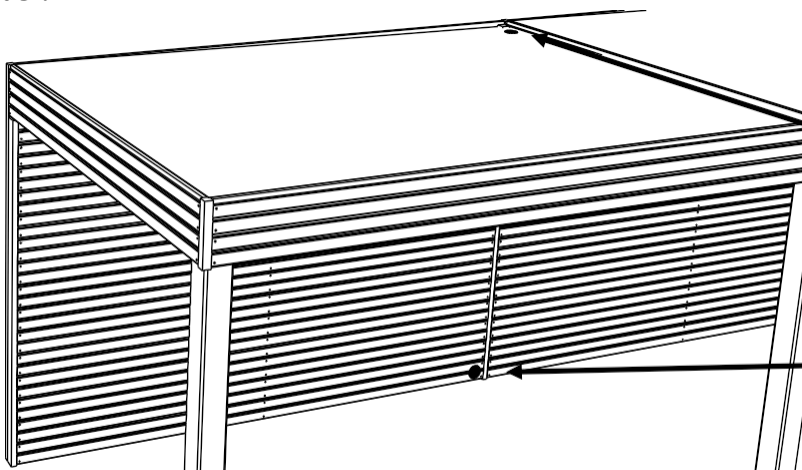

Place the gutter at the lowest point of the roof. See also step 27.

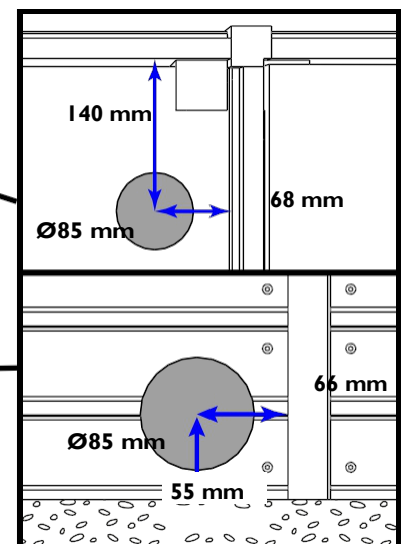

**b1.** Garden shed (and extension)

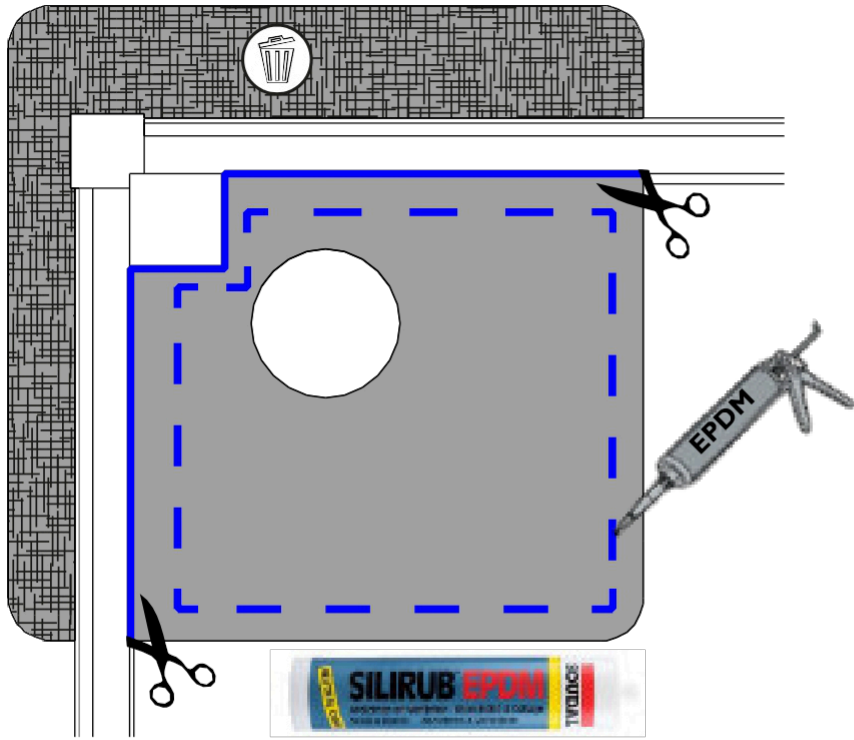

Use the supplied EPDM glue.  
Apply between the roof penetration and the OSB.

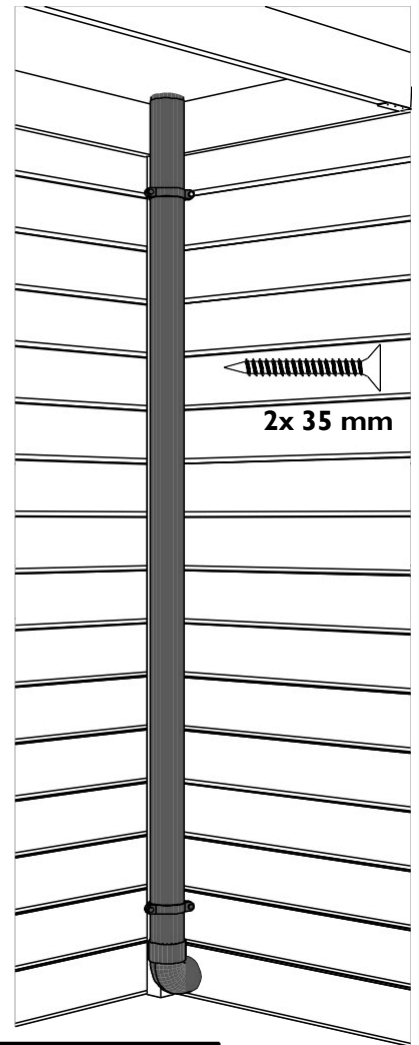

**b2.** 2nd extension

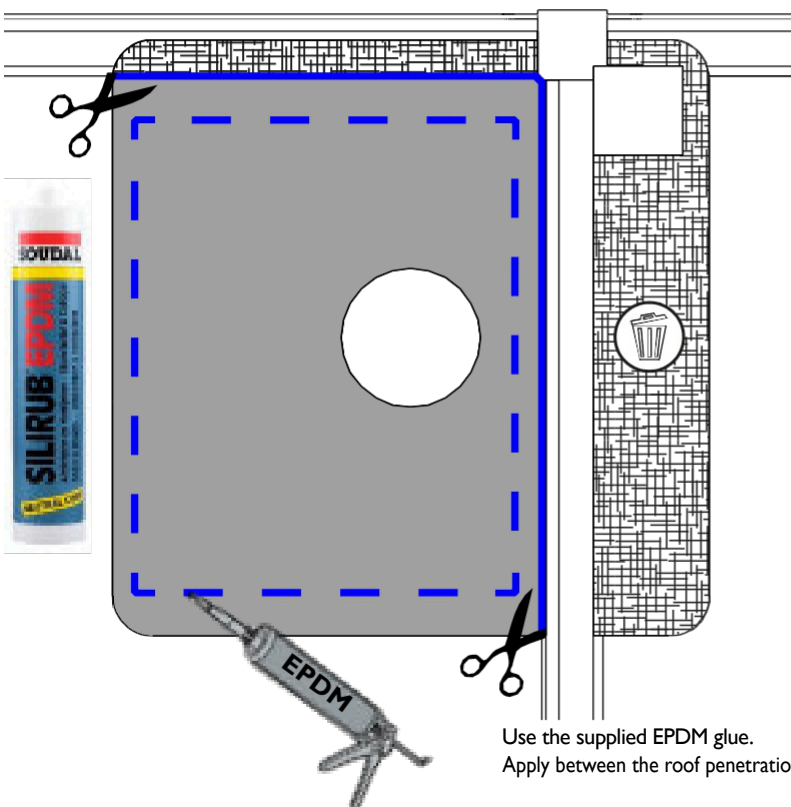

Use the supplied EPDM glue.  
Apply between the roof penetration and the OSB.

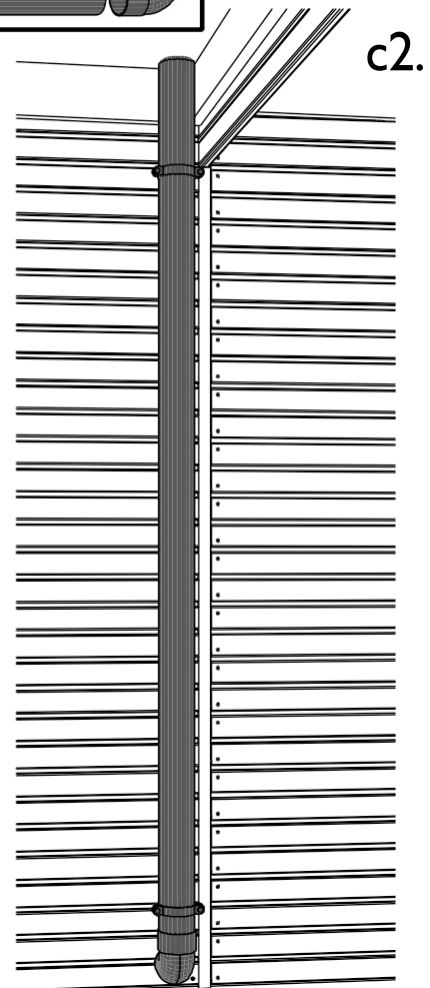

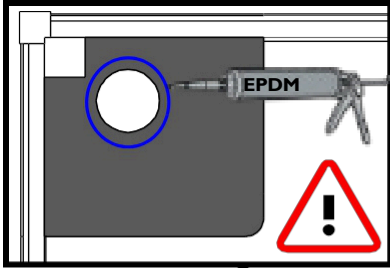
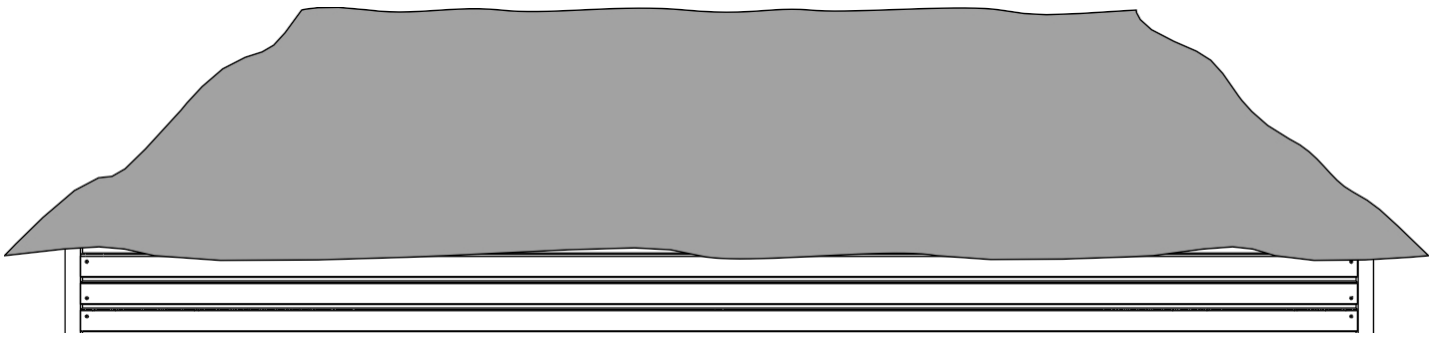

Apply EPDM glue in regular spaced beads.  
Apply a continuous circle around the drain.

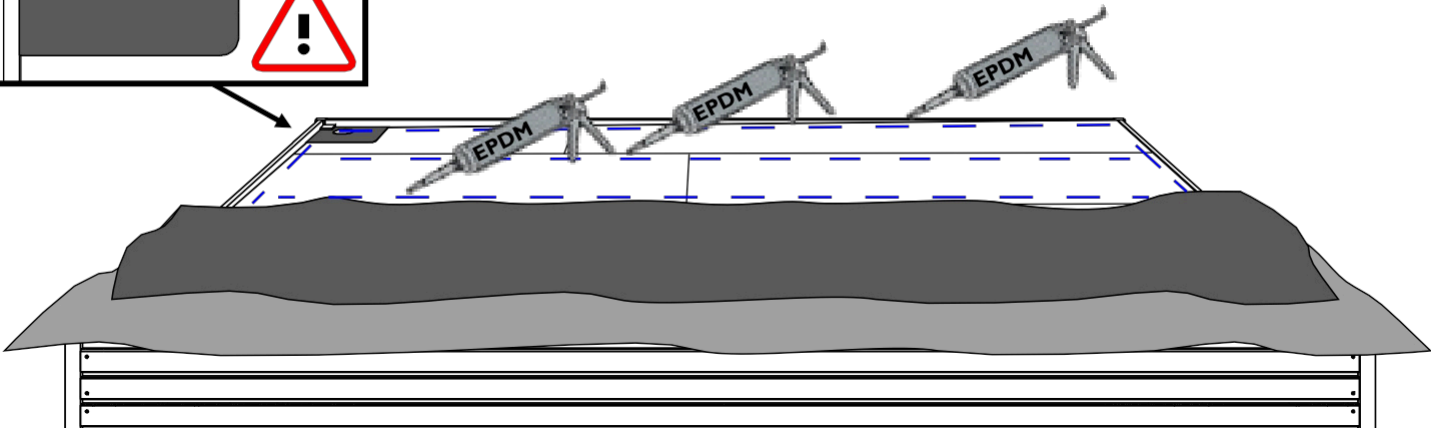

The EPDM for the garden shed and extension(s) consists of several sheets; glue these together with a full, continuous bead of glue.

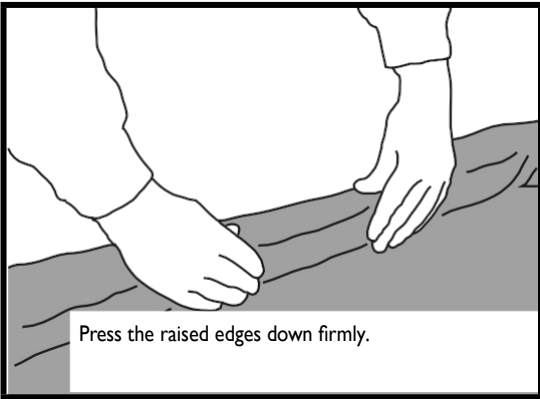

Press the raised edges down firmly.

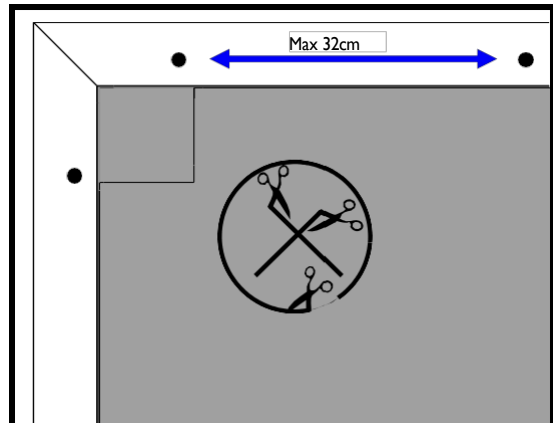
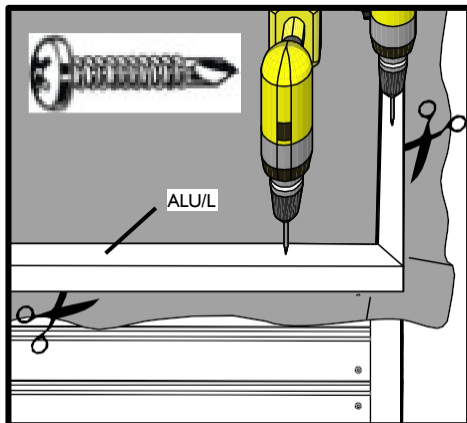
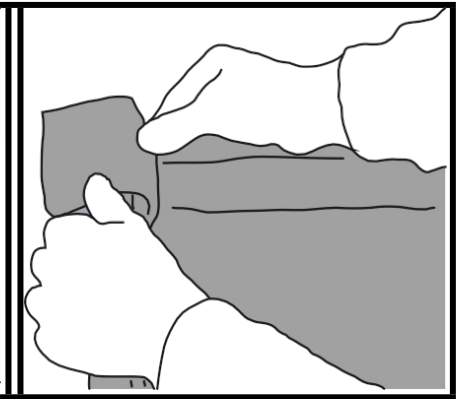
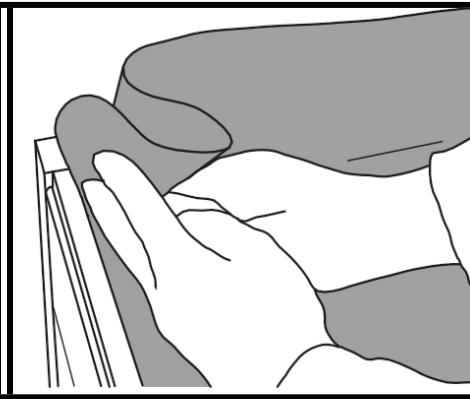

38.

Installation of the plexiglass

a.

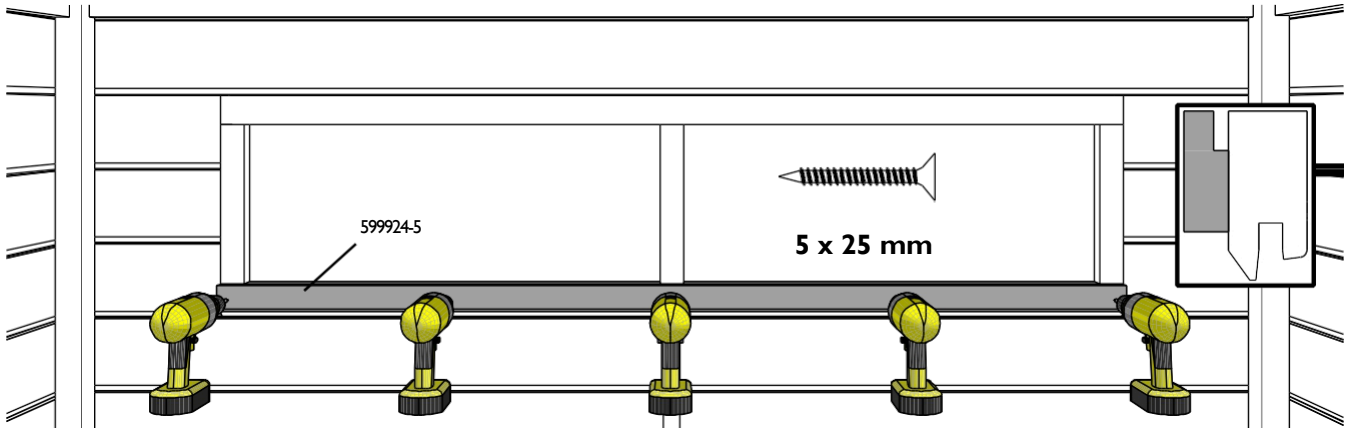

b.

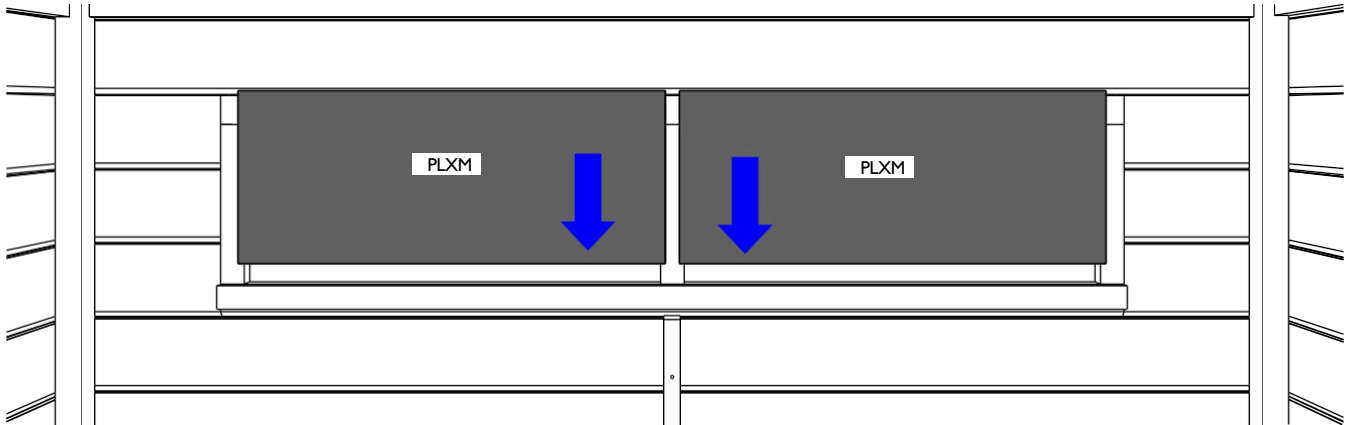

c.

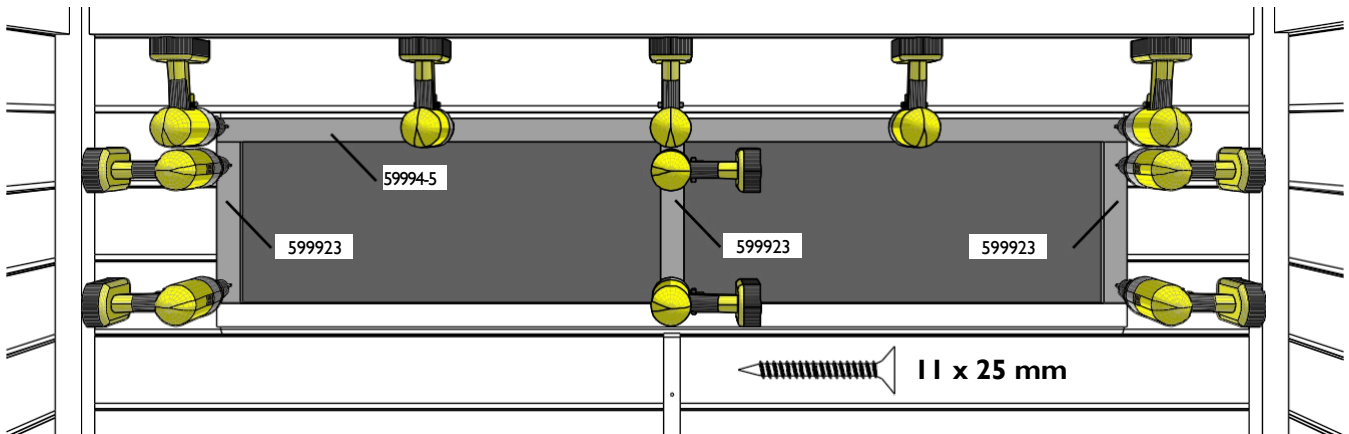

39.

Preparation for the sliding door

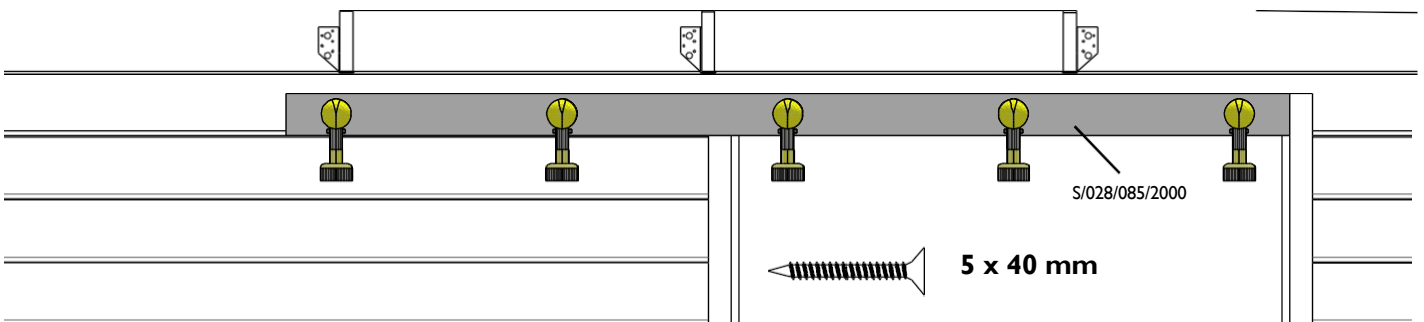

40.

Preparation for the sliding door

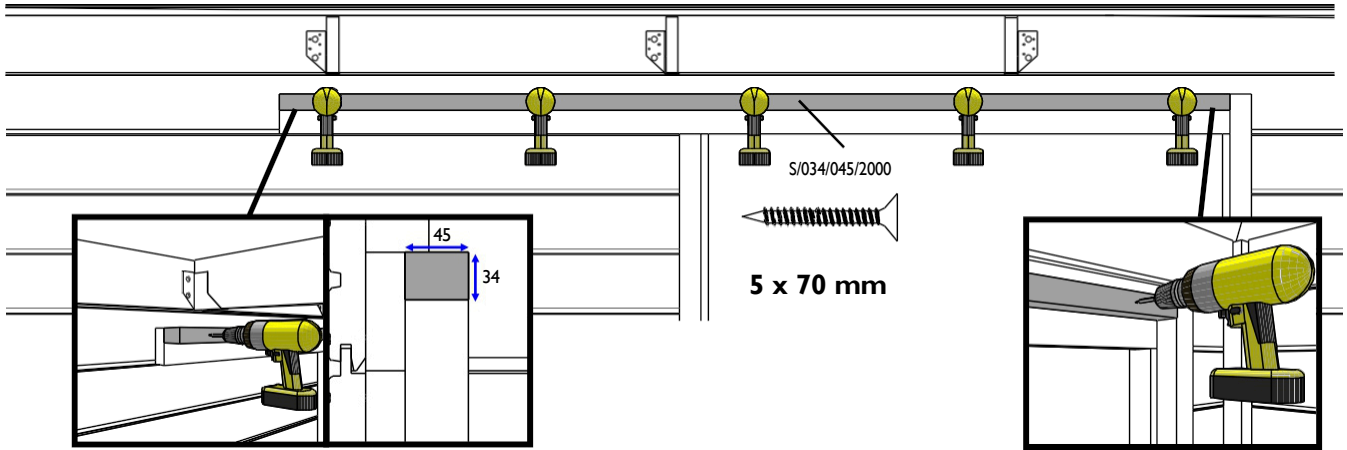

41.

Rail mounting

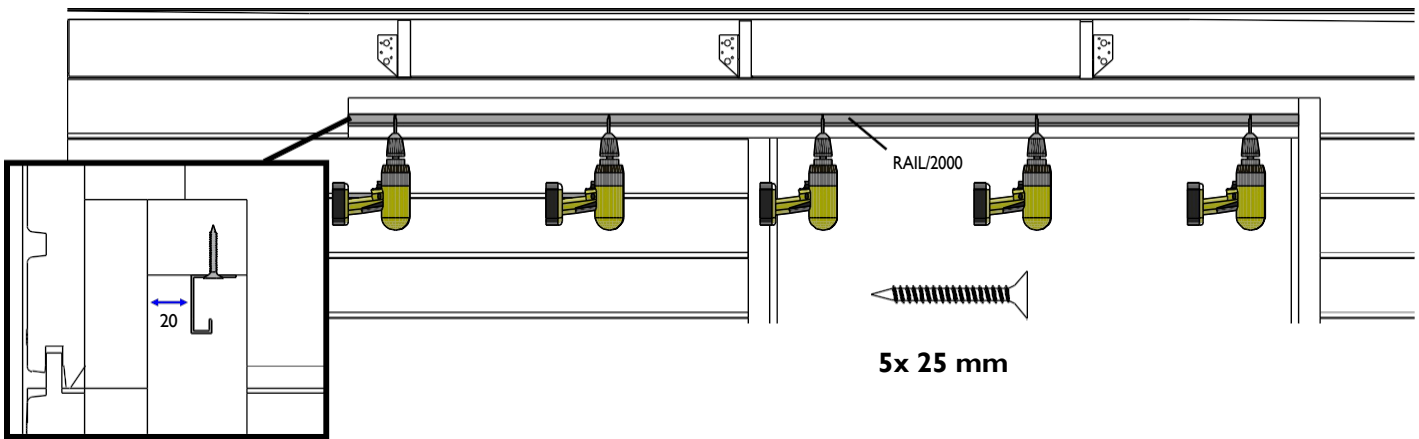

42.

Installation of door threshold

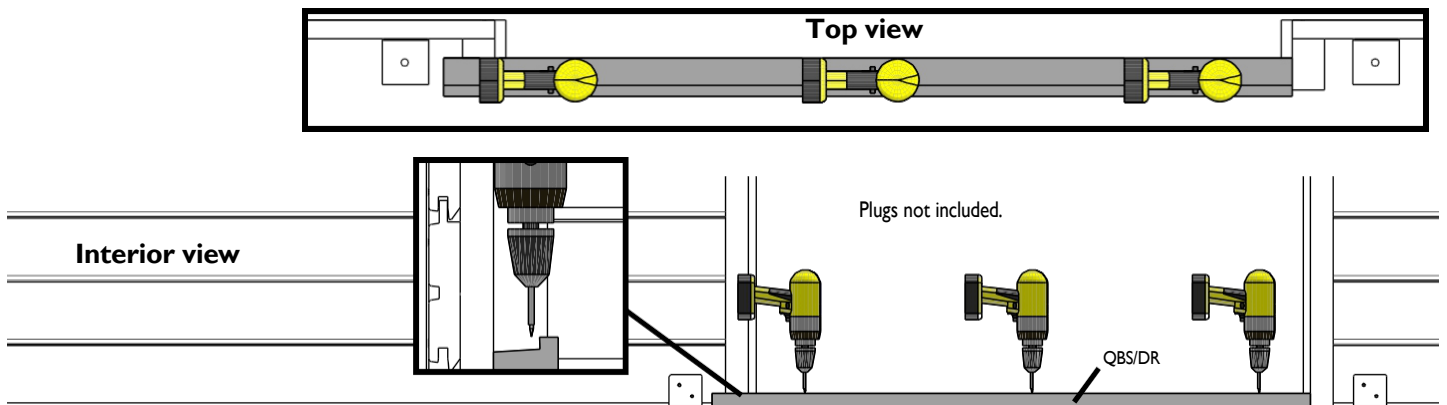

Place the guide wheels on the threshold, one on the far left and one on the far right.



43.

Mounting the rollers

Please note the position of the lock (L or R).

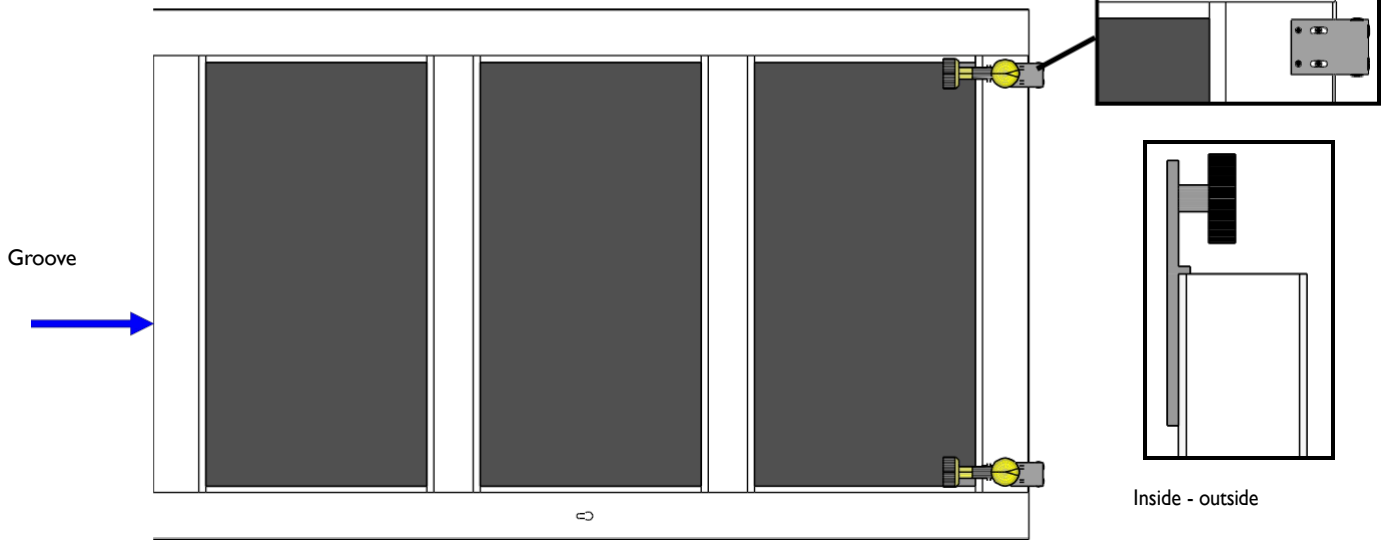

44.

Hanging the door

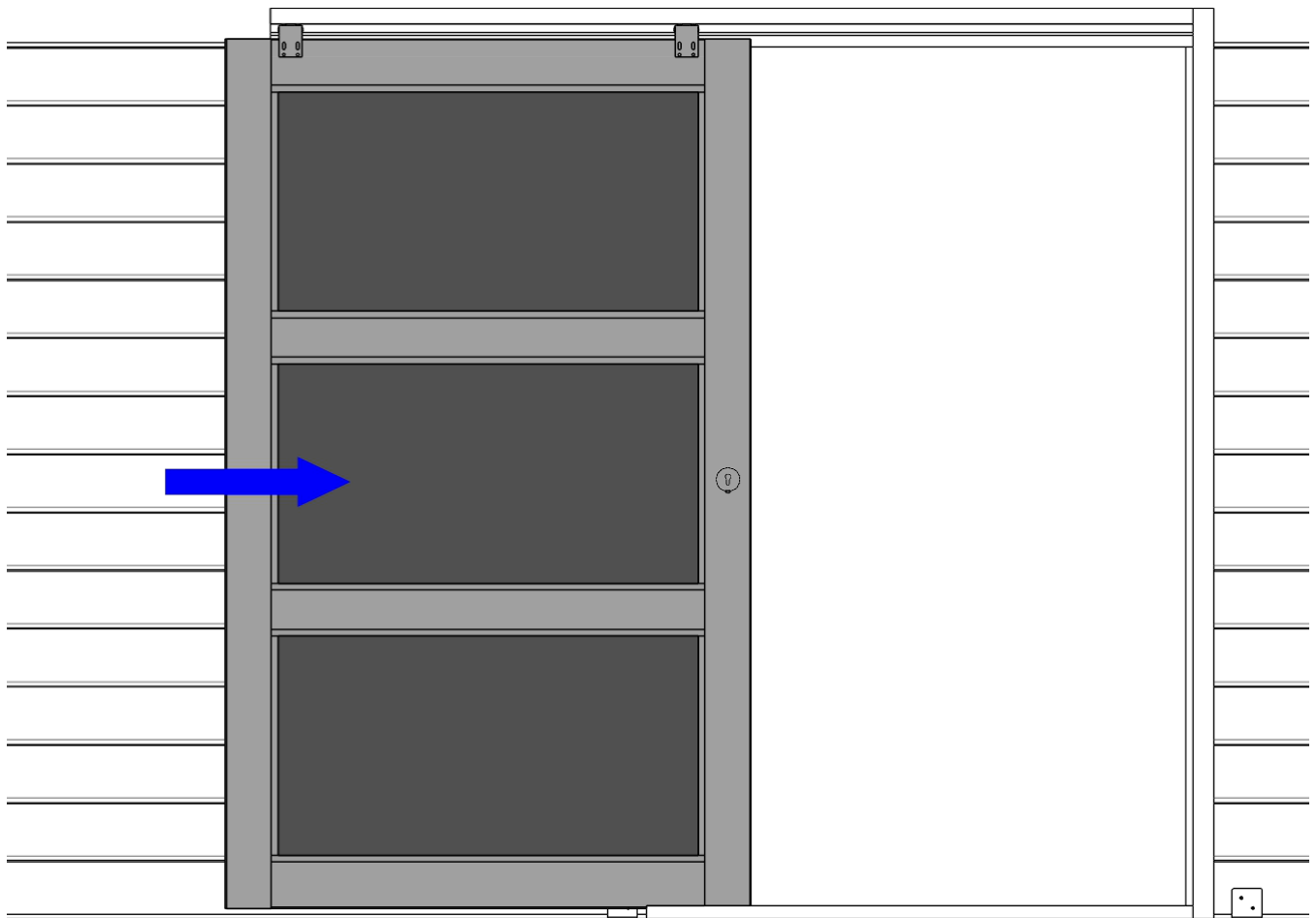

Hang the door in the rail, mount the lock, cylinder and handle on the outside.

45.

Mounting the cover strip

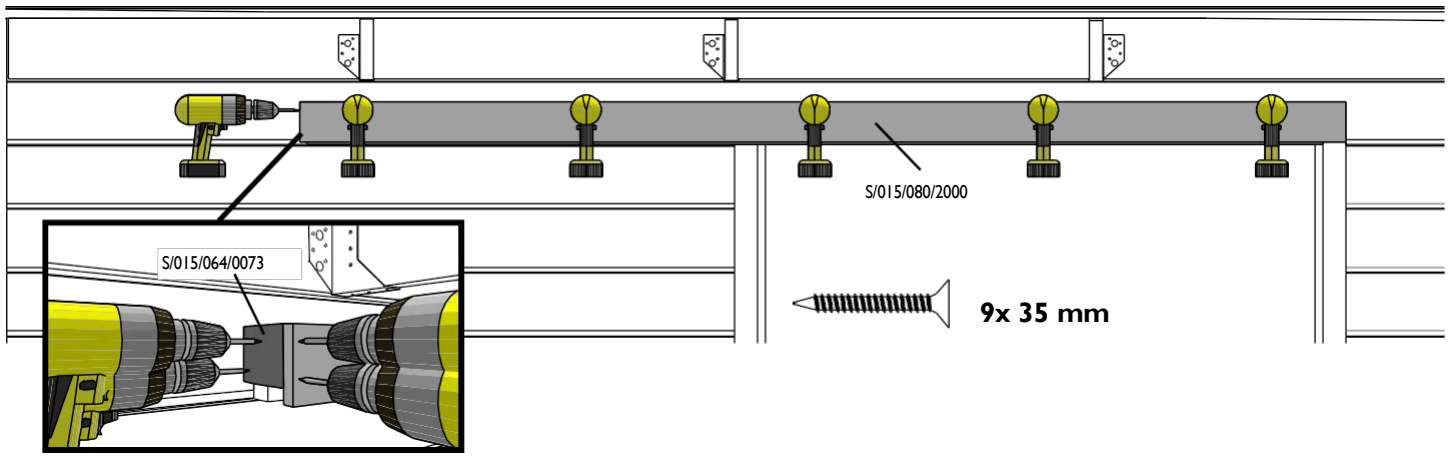

46.

Trim strip on the outside above the door

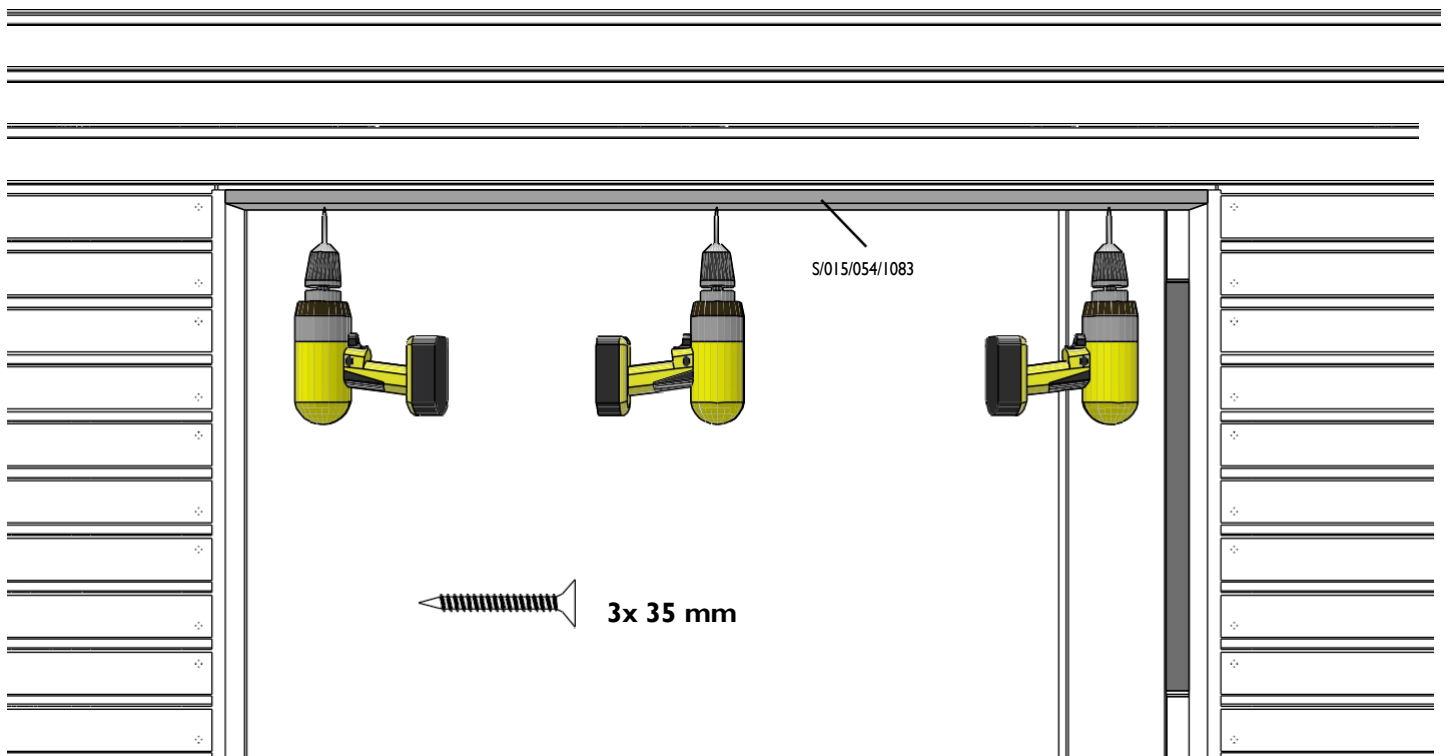

47.

Seal the following areas with silicone (not supplied):

- The joint between the garden shed and its base on the outside,
- Around the plexiglass,
- The vertical joint between the planks and the corner profiles.

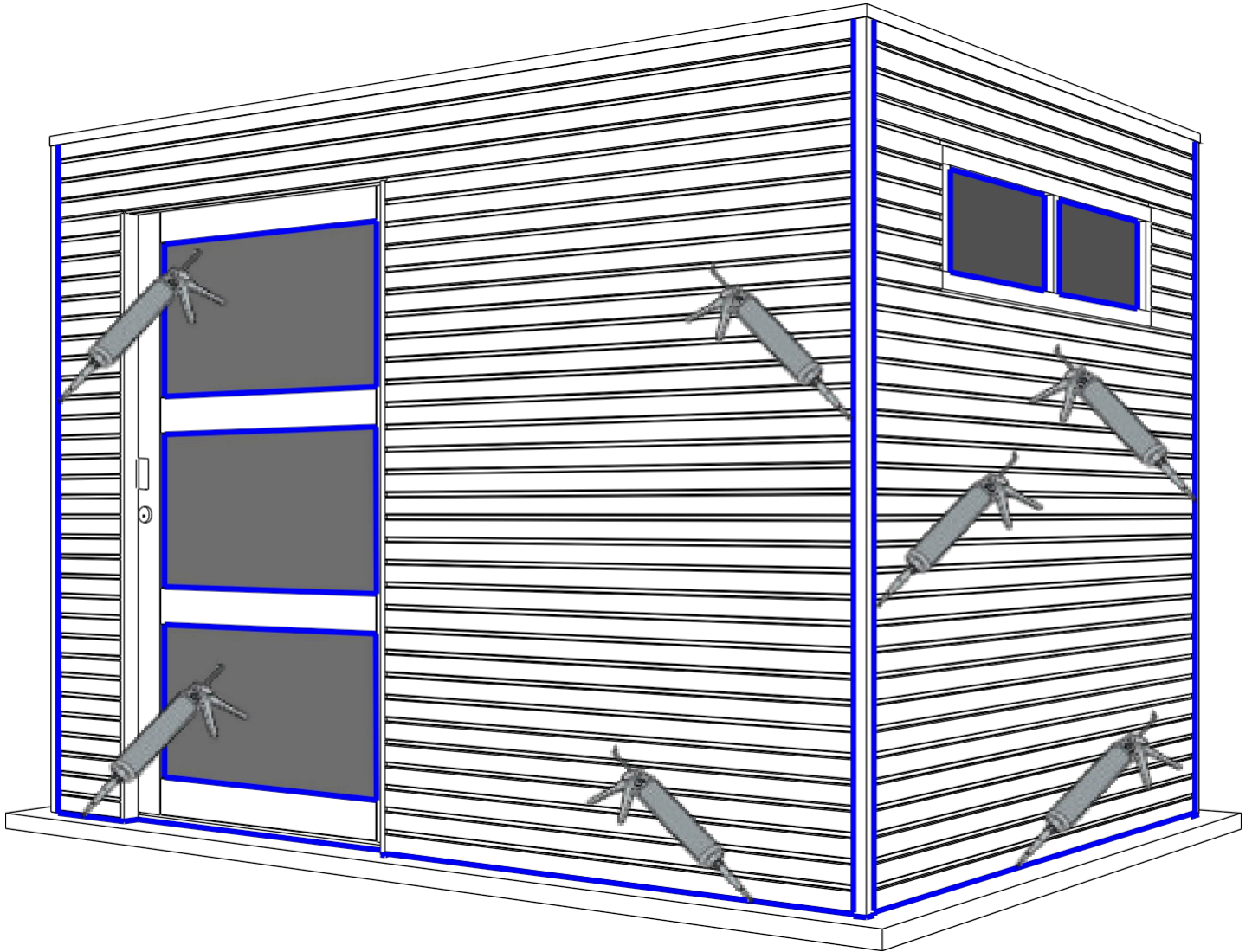

- Product liability applies only if the garden shed has been assembled in full compliance with these assembly instructions.
- The customer is responsible for ensuring adequate anchoring to the ground (protection against stormy weather).
- Check regularly to **ensure** that the **rainwater drainage remains clear and free.**

# Ceiling option

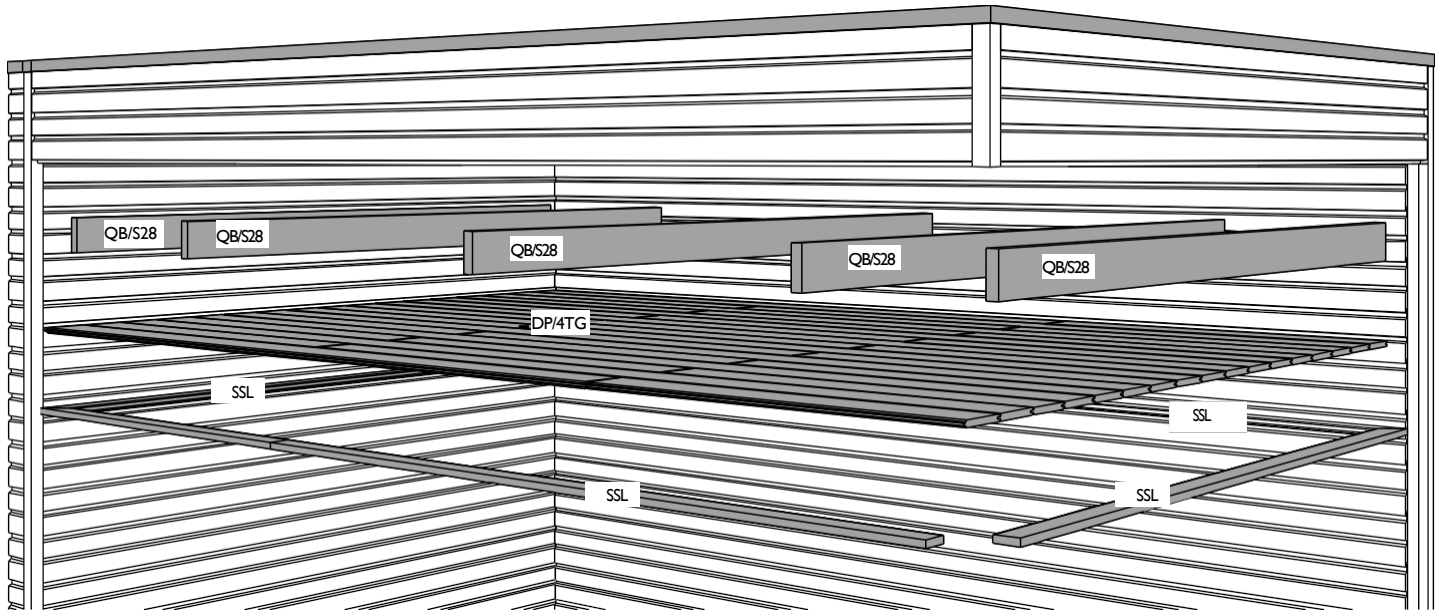

1.

 5 pcs/50 mm

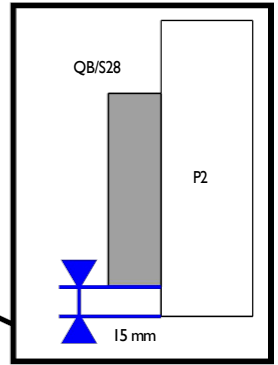
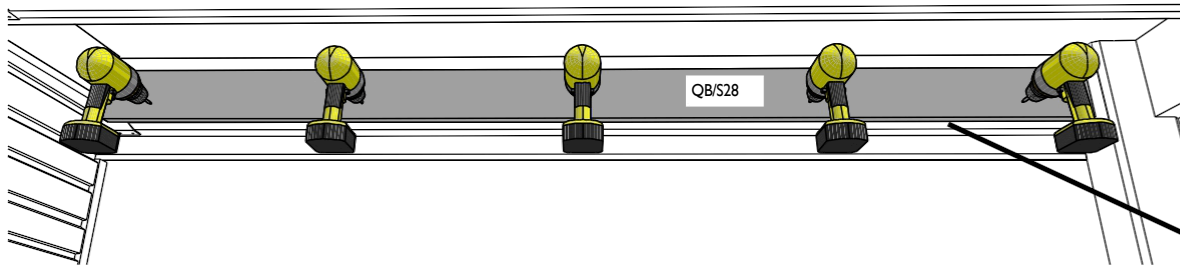

2.

 20 pcs/50 mm

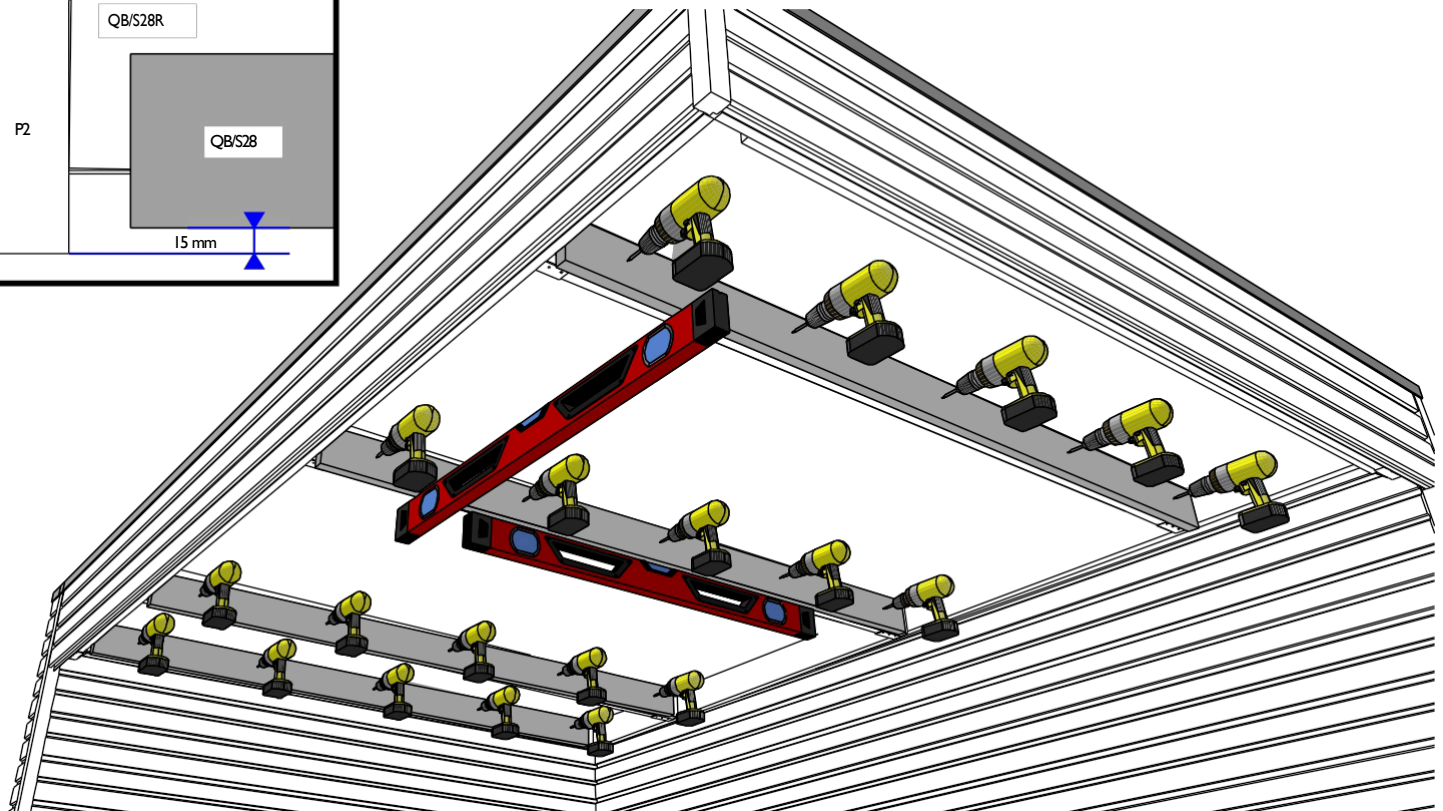
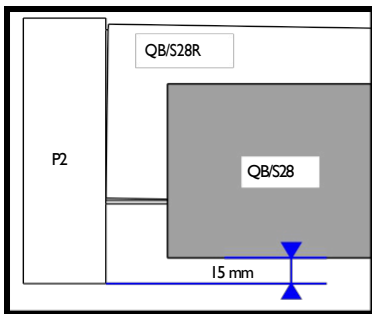

3.

 2.5 x 50 mm

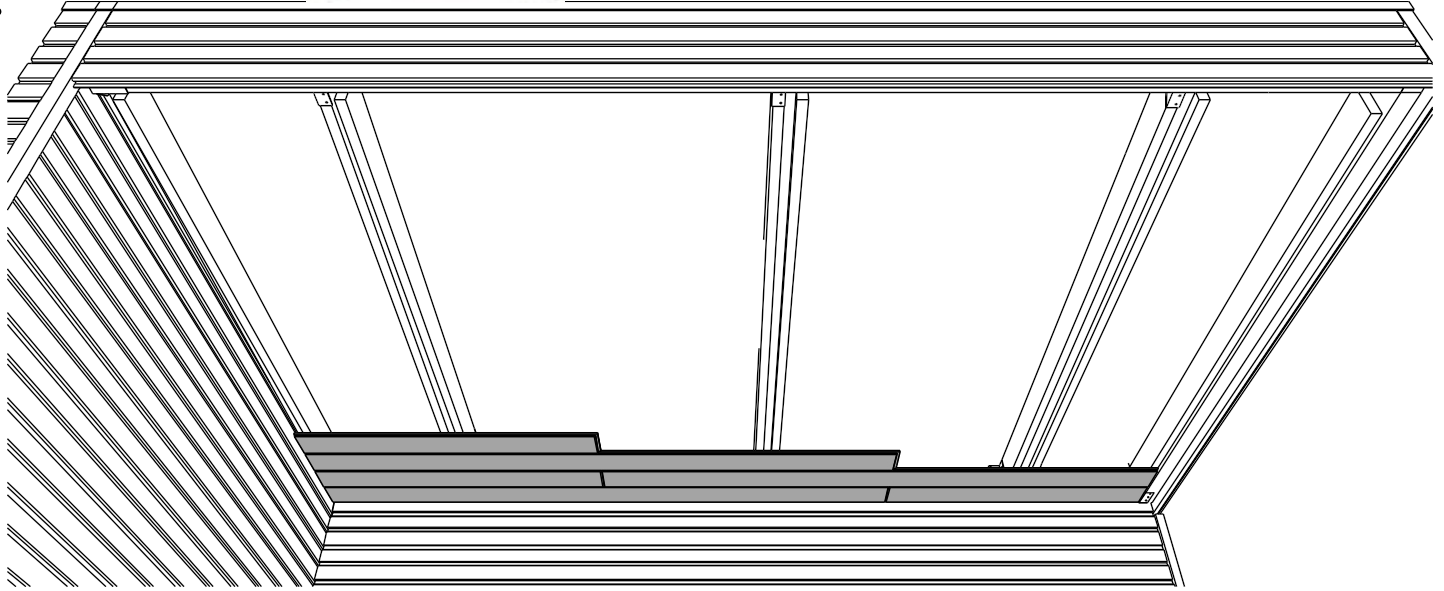

4.

 2.5 x 50 mm

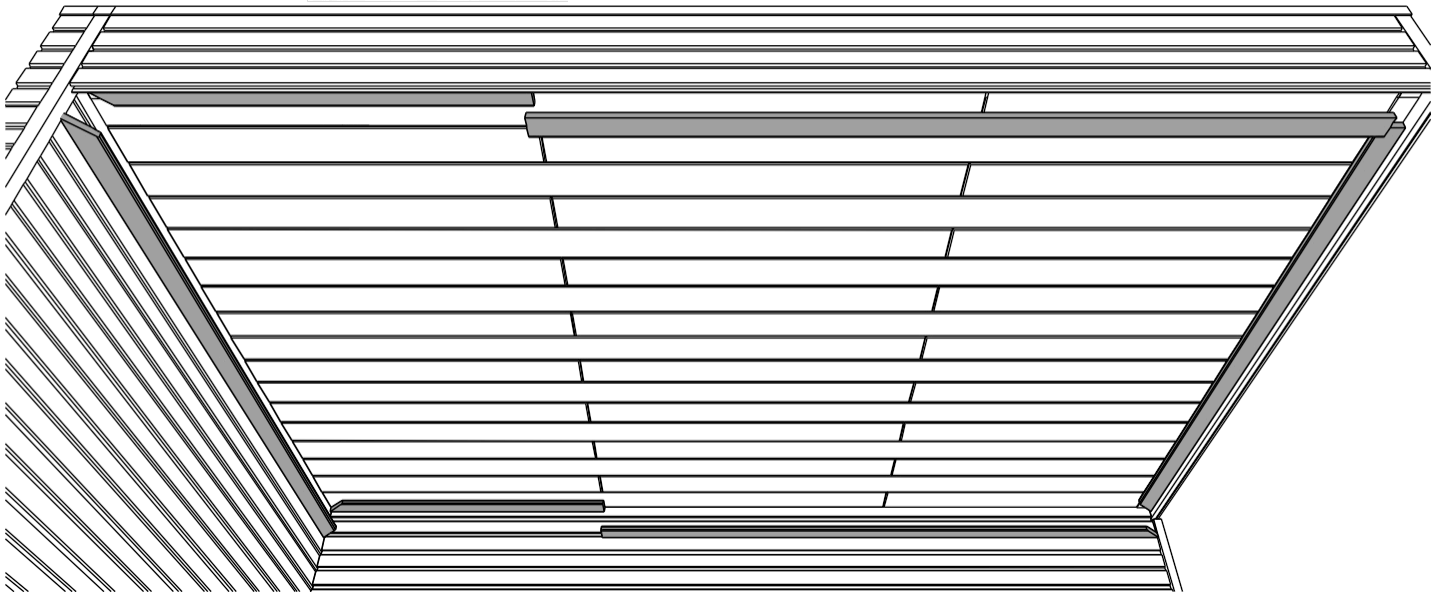

5.

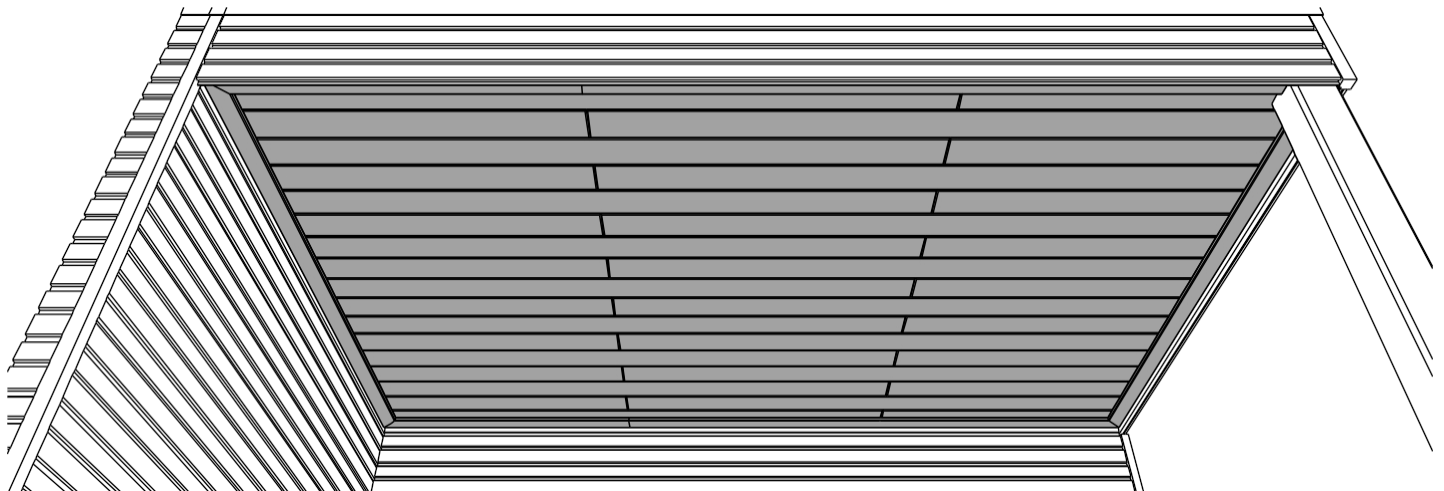



## **WARRANTY**

The product is made of wood, a natural product that, due to its outdoor placement, will continue to "live" and therefore requires ongoing attention. Assembly, treatment and anchoring will be carried out by or on behalf of the customer. Gardenas is therefore responsible for and provides a warranty on the product and its components themselves, but not for the consequences of incorrect assembly, missing or inadequate anchoring, or incorrect or inadequate maintenance.

### **How long?**

Unless otherwise stated, Gardenas offers a 5-year warranty on its products. Fittings and roofing are covered by a 2-year warranty. Products sold as pressure-impregnated are covered by an extended 10-year warranty against rot, mould and insect damage to the wooden parts.

The warranty period starts from the date of purchase.

### **What is covered by the warranty?**

- The structural design of the product for safe and normal use.
- The correctness of the parts in terms of quantity and shape upon delivery. Any deviations must be reported no later than 14 days after delivery.
- The warranty is limited to the replacement of defective, damaged or unusable parts.

### **What is not covered by the warranty?**

- Costs of (re)installation, production, assembly, treatment.
- Parts that are no longer in their original condition.
- Defective parts that were installed anyway.
- Minor deviations from the natural material, whether or not specified in the manual, which do not compromise the stability and expected lifespan of the product (e.g. knots, cracks, discolouration, slight deformations that can be assembled and will have no impact after assembly or will be invisible after assembly, etc.).
- Damage, deformations or defects resulting from ignoring to strictly follow the advice and instructions in the product manual and/or incorrect or careless use of the product, as well as damage caused by poor foundations.
- Damage and degradation and their consequences due to inadequate treatment of the product.
- Damage caused during transport and storage, whether or not due to extreme humidity, if transport and storage were not carried out under Gardenas' management.
- Damage caused by third parties, animals, insects (except if the product was delivered pressure-impregnated) and termites.
- Natural ageing or discolouration of the product.
- Damage caused by a roof load (e.g. snow) of more than 50 kg/m<sup>2</sup>.
- Direct or indirect damage to items and materials stored in or under the product.
- Consequences of force majeure: storms, natural disasters, floods, vandalism, etc.

### **Parts availability and delivery**

Gardenas guarantees the availability of all parts or a valid alternative for each part for up to 5 years after purchase of the product, regardless of whether the part is still under warranty or not.

Gardenas will make every effort to provide any replacement parts as quickly as reasonably possible. Gardenas will deliver the parts in the same manner and to the same location as it delivered the original product.

## POINTS TO NOTE



**ATTENTION!** The planks must be glued to the corner profiles using the supplied wood glue. Gluing is mandatory to ensure the garden shed remains square. Assembly without glue will void the warranty. As long as the glue isn't dry, you can still make small adjustments; not afterwards! So make sure you build the walls perfectly plumb from the start! Use the measuring tapes to mark the corner profiles and respect the correct spacing when installing the wall planks. If you do not do this, the planks will not be able to 'move' and the walls may warp due to fluctuations in ambient humidity. Furthermore, the openings for doors and windows will not fit and the overall height will be incorrect.

